

Telemetry Balkan doo Beograd

O2D R5

Robot Assembly Manual

Prepared By:

Sergei Loshchilov

Dmitry Chistov

Andrey Stepanov

v 0.11.0

Beograd, Serbia

2026-05-06



Version History

Version	Date	Authors	Description
0.1.0	2026-05-06	Sergei Loshchilov	Initial Document Started
0.2.0	2026-05-06	Sergei Loshchilov	Added BOM
0.3.0	2026-05-06	Dmitry Chistov	Declared the mechanics assembly steps
0.4.0	2026-05-07	Andrey Stepanov	Declared the software installation steps
0.5.0	2026-05-12	Sergei Loshchilov	More mechanical components are described in BOM
0.6.0	2026-05-13	Dmitry Chistov	Added Images to BOM
0.7.0	2026-05-13	Sergei Loshchilov	Added scheme of the battery and the battery lid mounting
0.8.0	2026-05-14	Sergei Loshchilov	Added the tech draw of BMS and Main Board installation
0.9.0	2026-05-15	Sergei Loshchilov	Added Electronics Assembly Scheme
0.10.0	2026-05-18	Sergei Loshchilov	Added the final assembly steps for mechanics
0.11.0	2026-05-18	Andrey Stepanov	Populated the software installation instructions



Contents

Version History	2
Contents	3
1. Overview	5
2. Bill of Materials	6
3D Printed Components.....	6
Mechanical Components.....	7
Electronic Components.....	9
3. Mechanics Assembly	14
3.1 Mount the contact plates into the O2D R5 Bumper with self-tapping screws.....	14
3.2 Mount the bumper into O2D R5 Body.....	15
3.3 Install the battery into the battery compartment of O2D R5 Body, Mount the battery compartment lid.....	16
3.4 Install JGA25-370 motors into O2D R5 Body.....	17
3.5 Install BMS into O2D R5 body.....	18
3.7 Install the Main board into O2D R5 Body.....	19
3.8 Install Lidar into O2D R5 Cover.....	20
3.9 Install Lidar Communication Module into PT5 Cover.....	21
3.10 Install the LED lens and the LEDs into O2D R5 Cover.....	22
3.11 Install Switch Button and Push Buttons into O2D R5 Cover.....	22
3.12 Install the Depth Camera into O2D R5 Cover.....	23
3.13 Install M4x12 Nuts into O2D R5 Cover.....	24
3.14 Mount O2D R5 Cover on O2D R5 Body.....	25
3.15 Mount Wheels.....	26
4. Electronics Assembly	27
4.1 Assemble the battery.....	27
4.2 Install RP2040 into the Main Board.....	28
4.3 Install GY-521 IMU module into the Main Board.....	29
4.4 Install 4xDRV8871 modules into the Main Board.....	30
4.5 Install Mini560 5V 5A Step Down DC-DC Converter into the MainBoard.....	31
4.6 Install Raspberry Pi 5 into the Main Board.....	32
4.7 Connect the battery sampling cable to BMS.....	33
4.8 Connect the negative contact of the battery pack to B- contact of BMS.....	33
4.9 Connect P- contact of BMS to the Main Board “P-” Terminal.....	34
4.10 Connect Battery + Wire to the Main Board “Battery +” Terminal.....	35
4.11 Connect Charger + and Charger - Plate wires to the MainBoard Charger terminal.....	36
4.12 Connect Daly BMS UART port to BMS UART port of the MainBoard.....	37
4.13 Connect On/Off Switch to On/Off Terminal of the MainBoard.....	38
4.14 Connect Functional Buttons and LEDs to the peripheral terminal of the Main Board....	39
4.15 Connect Raspberry Pi 5 to 5V 5A terminal of the MainBoard.....	40



4.16 Connect the motors to the Main Board.....	41
4.17 Review the Main Board Wiring.....	42
4.18 Connect the Depth Camera to the Raspberry Pi with USB Type-C Cable.....	43
4.19 Connect D500 Lidar Communication Module to the Raspberry Pi with USB Type-C Cable.....	44
4.20 Raspberry Pi Pico RP2040 to the Raspberry Pi with USB Type-C Cable.....	45
5. Software Installation.....	45
5.1 Download Ubuntu 24.04 Server image install it through Balena Etcher on USB flash drive.....	45
5.1 Insert the USB Flash Drive into Raspberry Pi5, and run Ubuntu 24.04 installation process.....	45
5.2 Install Docker dependencies.....	45
5.3 Configure Docker User Access Rights.....	46
5.4 Create Docker files for ORB container.....	46
5.5 Launch Docker Container.....	47
5.5.1 Launch the Container.....	47
5.5.2 Check the Container Status.....	47
5.6 Confirm the software is running.....	47
6. Limitation of Liability.....	48
7. Support.....	48
8. Conclusion.....	50



1. Overview

The O2D R5 is a compact autonomous robotic platform developed by Telemetry Balkan doo Beograd for indoor robotics research, autonomous navigation, and AI-driven robotic applications. The platform integrates a four-wheel drive mechanical system, embedded control electronics, depth sensing technologies, and onboard computing into a modular and serviceable robot chassis.

The robot is designed around a Raspberry Pi 5 single-board computer combined with an RP2040 microcontroller and a custom O2D R5 Main Board. This architecture enables real-time motor control, sensor acquisition, power management, and high-level robotic software execution using modern robotics middleware and containerized software infrastructure.

The O2D R5 includes the following key subsystems:

- Four independently driven JGA25-370 DC motors with rotary encoders
- Intel RealSense D435 depth camera for visual perception
- LDLidar D500 lidar sensor for environment scanning and mapping
- DALY Smart BMS powered LiFePO4 battery system
- Custom electronics board integrating motor drivers, IMU, and power distribution
- Ubuntu 24.04 and Docker-based software environment running the ORB Robot Control Software

This manual provides detailed instructions for:

- Mechanical assembly of the robot body and chassis
- Electronics installation and wiring
- Battery and power system assembly
- Sensor and peripheral integration
- Software installation and Docker deployment
- Initial startup and verification procedures

The document is intended for engineers, technicians, developers, and researchers assembling and commissioning the O2D R5 robotic platform for development, testing, or operational use.



2. Bill of Materials

3D Printed Components

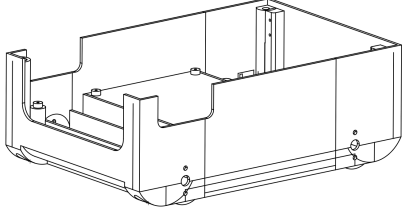
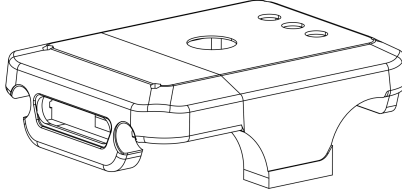
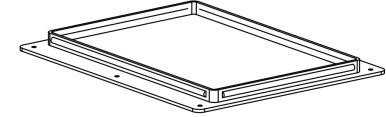
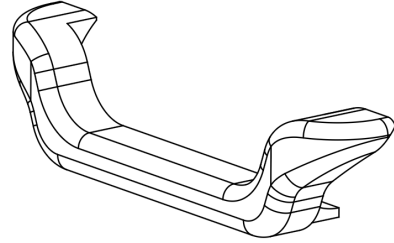
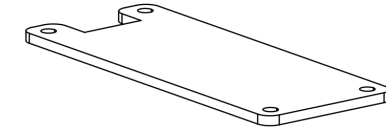
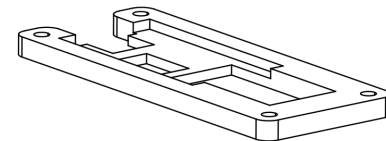
Type	Quantity	Image	Comments
O2D R5 Body	1		Keeps most of the schematics, motors and batteries
O2D R5 Cover	1		Keeps the depth camera, lidar, LEDs and buttons. Protects the schematics from the environment.
O2D R5 Battery Compartment Lid	1		Protects the batteries
O2D R5 Bumper	1		Protects the wheels and the body from the direct impact of the obstacles.
O2D R5 Secondary Board Holder	1		Allows to place the USB to Serial converter board of Lidar on O2D R5 Cover
O2D R5 Secondary Board Cover	1		Allows to place the USB to Serial converter board of Lidar on O2D R5 Cover



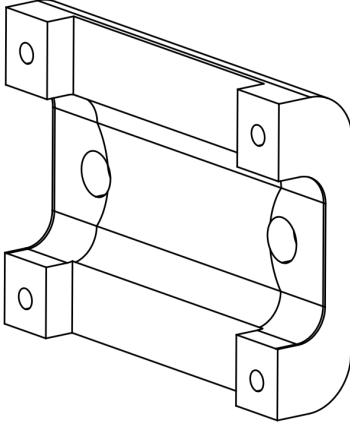





O2D R5 Camera Fixation Element	1		Allows to place and fixate the camera in O2D R5 Cover
--------------------------------	---	--	---

Mechanical Components

Type	Quantity	Image	Comments
Plastic/Rubber Wheel D=65mm	4		Usually available for purchase with JGA25-370 motors
JGA25-370 Shaft Coupling	4		





M4x8 Screws Pan Head DIN 7985	4		To joint O2D R5 Cover with O2D R5 Body
M4 12mm Metric Hex Coupling DIN 6334	4		To insert into O2D R5 Cover for further joining with O2D R5 Body
2x7 Self-Tapping Screws Pan Head DIN 7981	15		To mount the main board, Lidar, Battery Compartment Lid
2x7 Self-Tapping Screws Flat Head DIN 7981	2		To mount the charging plates to O2D R5 Bumper
M4x40 Screw Flat Head DIN 965	2		To joint O2D R5 bumper with O2D R5 Body
Washer M4 DIN 125	4		To fixate the charging wires



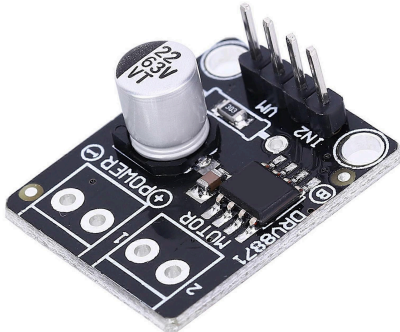
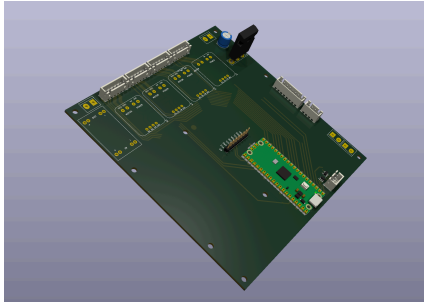
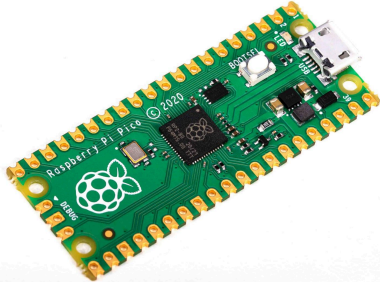

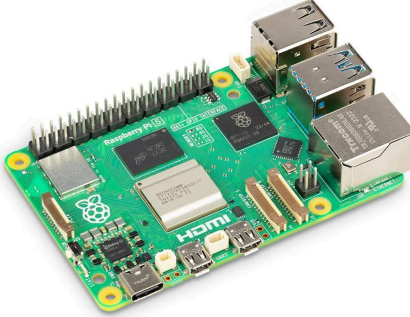

Electronic Components

Type	Quantity	Image	Comments
JGA25-370 Motor with the rotary encoder built-in	4		12 V 120 RPM
DRV8871 DC Motor Driver	4		
O2D R5 Main Board	1		
RP2040 Controller	1		







<p>Raspberry Pi5 8GB Single Board Computer</p>	<p>1</p>		
<p>GY521 MPU-6050 Gyroscope/Accelerometer module</p>	<p>1</p>		
<p>Idlidar D500 Lidar</p>	<p>1</p>		
<p>Intel Realsense D435 Camera</p>	<p>1</p>		





<p>Mini560 DC - DC Step Down Converter</p>	<p>1</p>		<p>5V 5A</p>
<p>DALY Smart BMS K-Series 4S 60A</p>	<p>1</p>		
<p>Accumulator Battery 32700 LiFePo4 3.7V 6000 mAh</p>	<p>4</p>		
<p>Diode Mosfet 30CPQ060</p>	<p>1</p>		
<p>Capacitor 25V 330uF</p>	<p>1</p>		



Push Button 16mm	2		Functional Button 1, Functional Button 2
Switch Button 16mm	1		On/Off Switch
LED	2		2-contacts 5mm
LED Lens	2		15 Degrees D=22 Height = 13.5

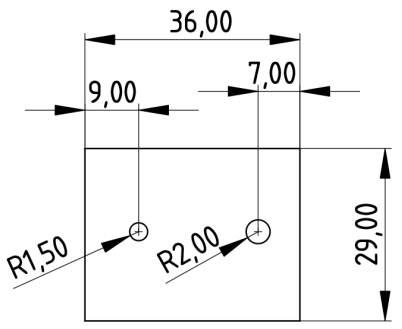

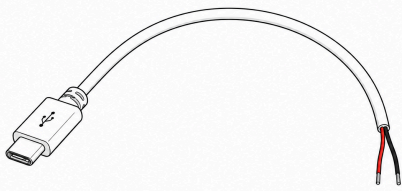
<p>Contact Plate 30x40x0.2</p>	<p>2</p>		<p>Material: Stainless steel, copper or brass</p>
<p>USB Type-A <-> Type-C Cable Power And Data Cable</p>	<p>3</p>		<p>To connect Raspberry PI Pico RP2040, USB to Serial Converter and Depth Camera to Raspberry Pi 5</p>
<p>Modified USB Type C cable with the power wires suitable for the terminal on PCB</p>	<p>1</p>		<p>To power up Raspberry Pi 5</p>



3. Mechanics Assembly

3.1 Mount the contact plates into the O2D R5 Bumper with self-tapping screws

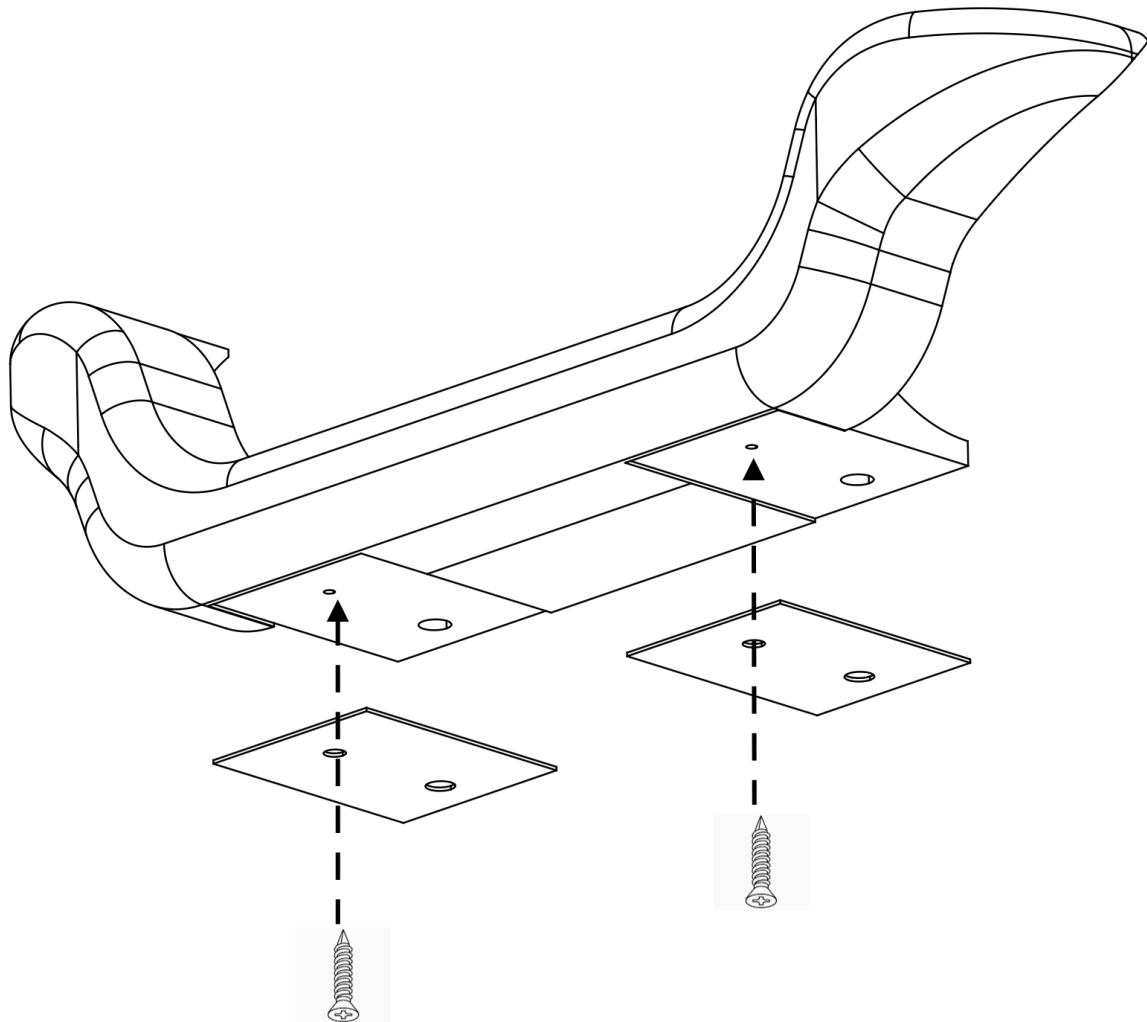



3.2 Mount the bumper into O2D R5 Body

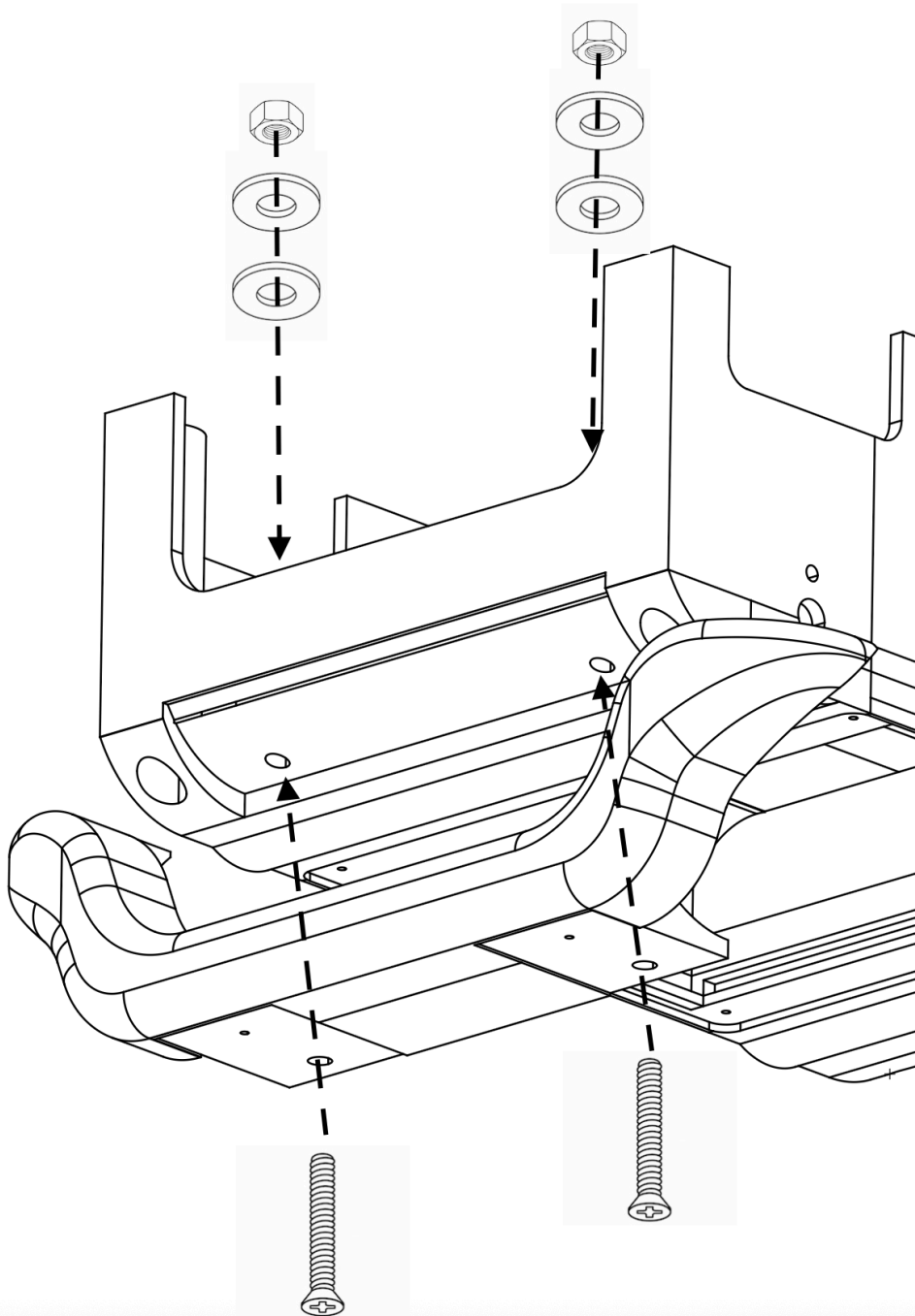

* Use 2 washers from the nut end. They are needed to fixate the charging wires.



3.3 Install the battery into the battery compartment of O2D R5 Body, Mount the battery compartment lid

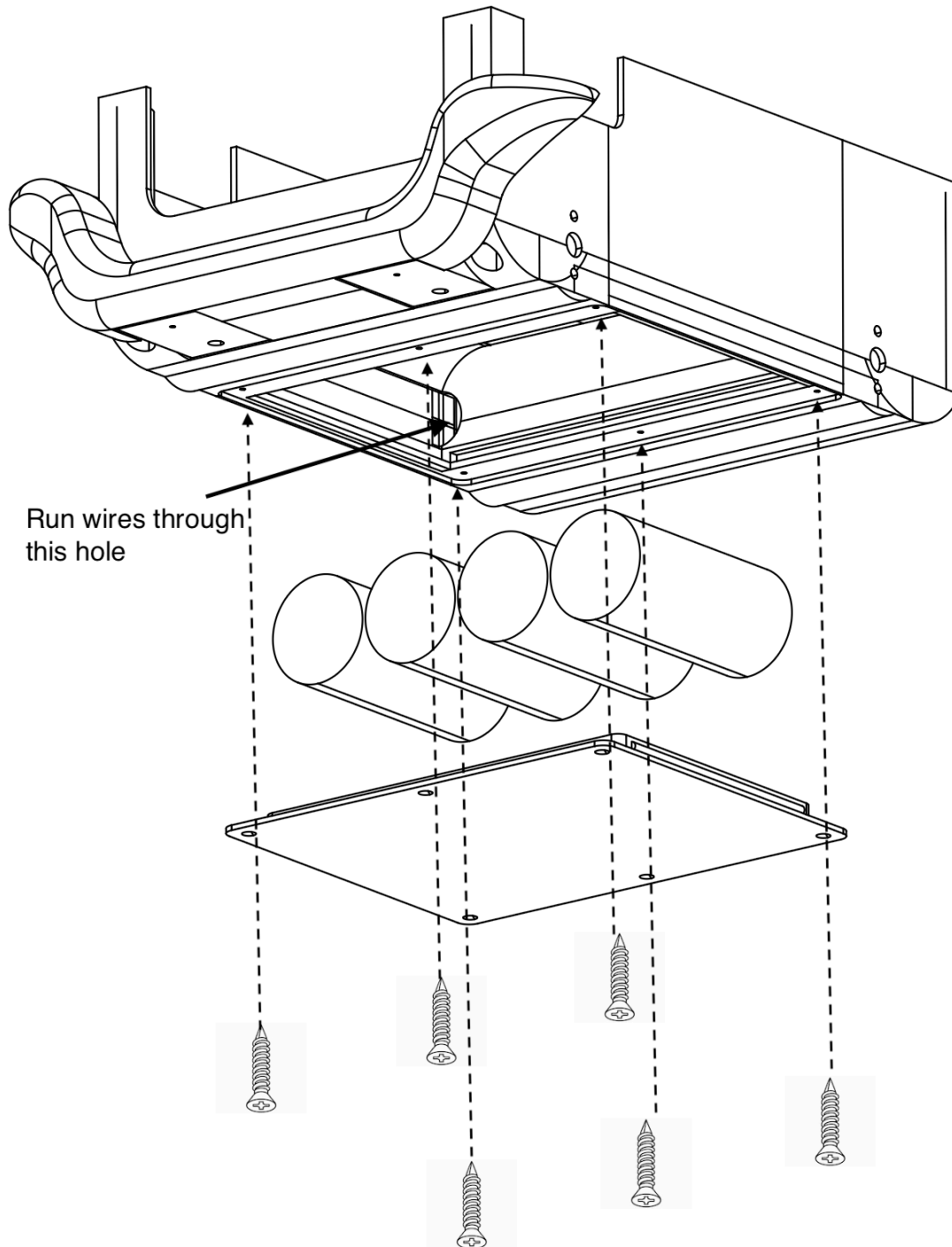

* Before this step the battery assembly must be done. See step 4.1



3.4 Install JGA25-370 motors into O2D R5 Body

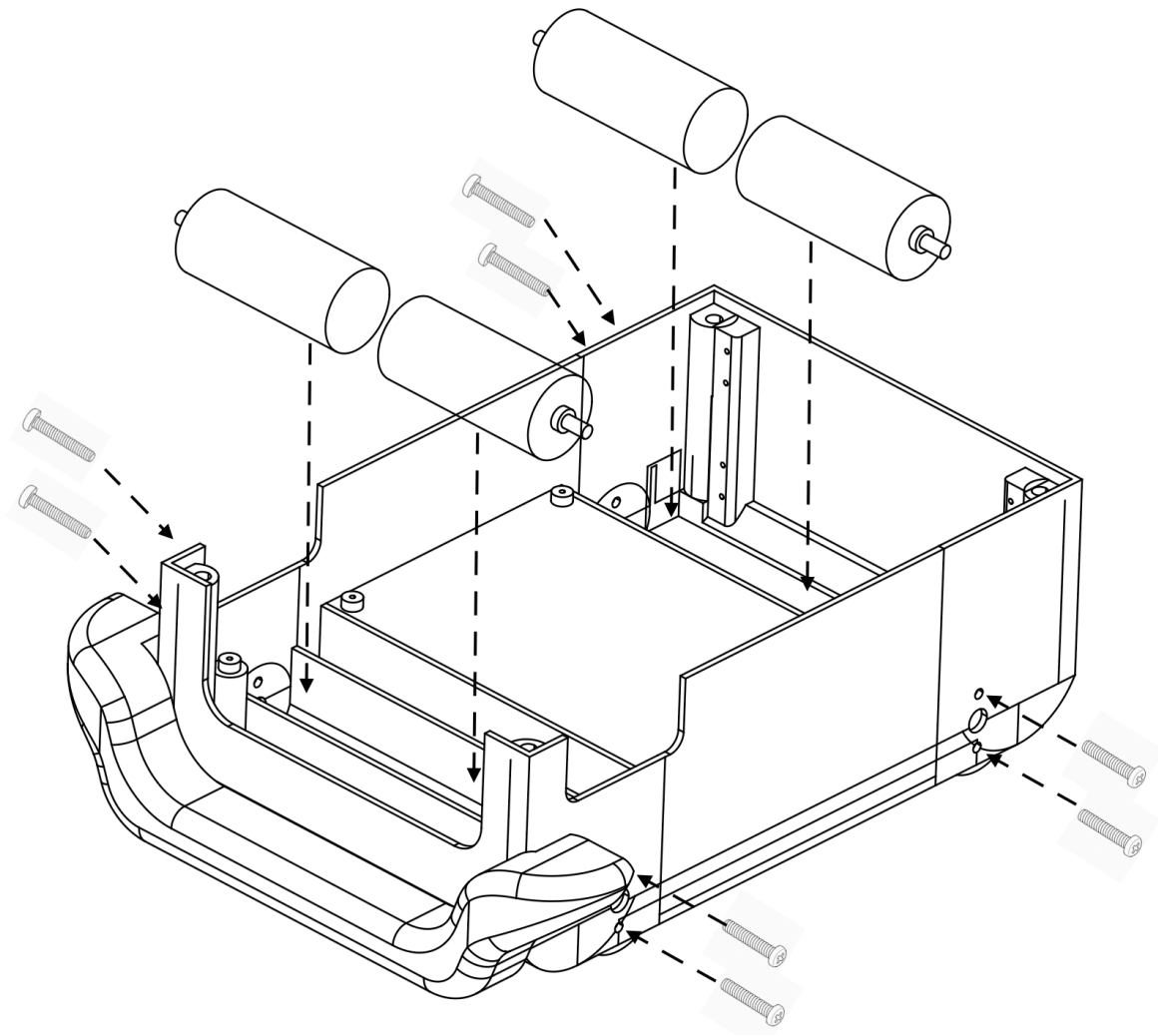



3.5 Install BMS into O2D R5 body

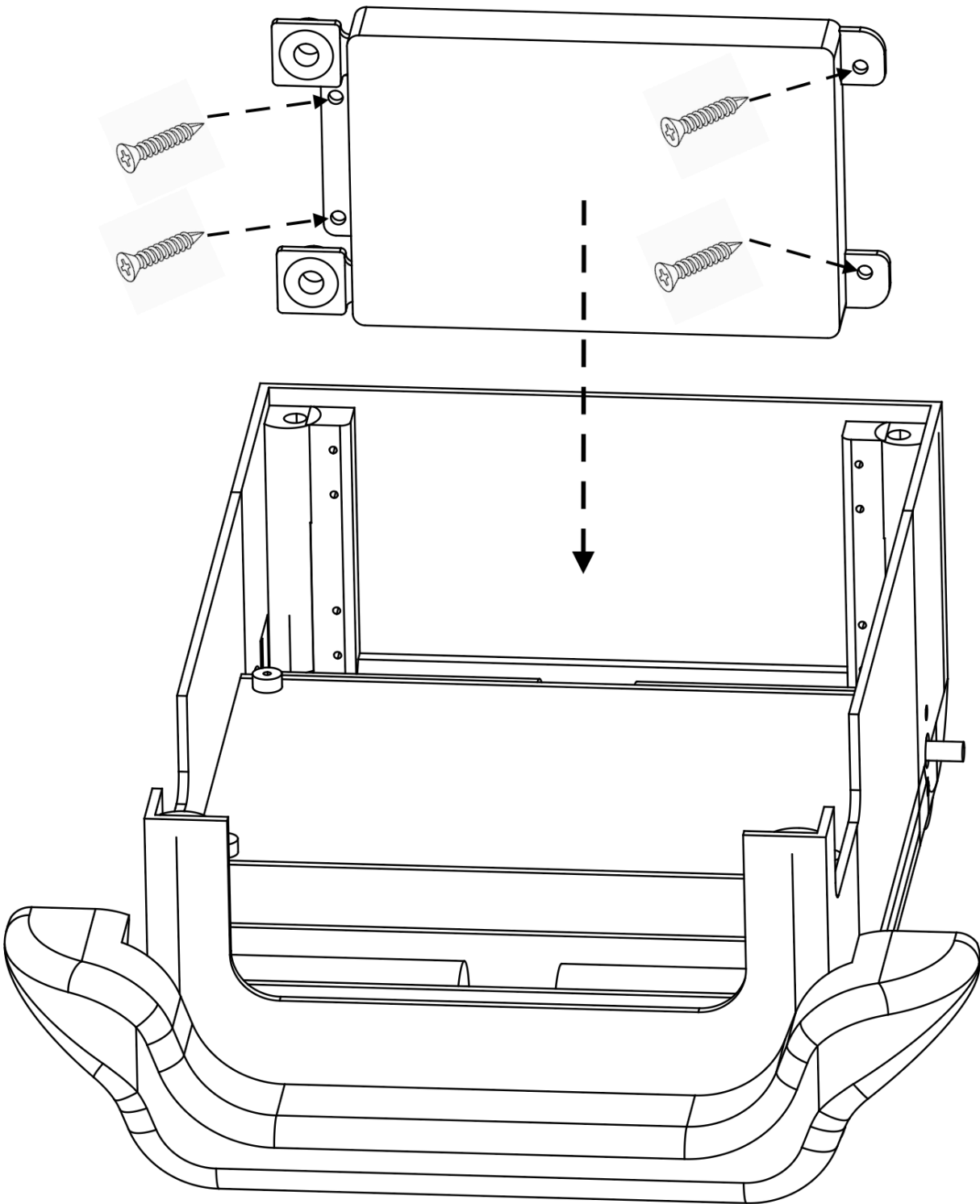



3.7 Install the Main board into O2D R5 Body

* Before installing the Main Board into O2D R5 Body, please install RP2040, Raspberry Pi 5, GY-521 IMU and 4xDRV8871 drivers into the Main Board (steps 4.2, 4.3, 4.4 and 4.5 of electronics assembly).

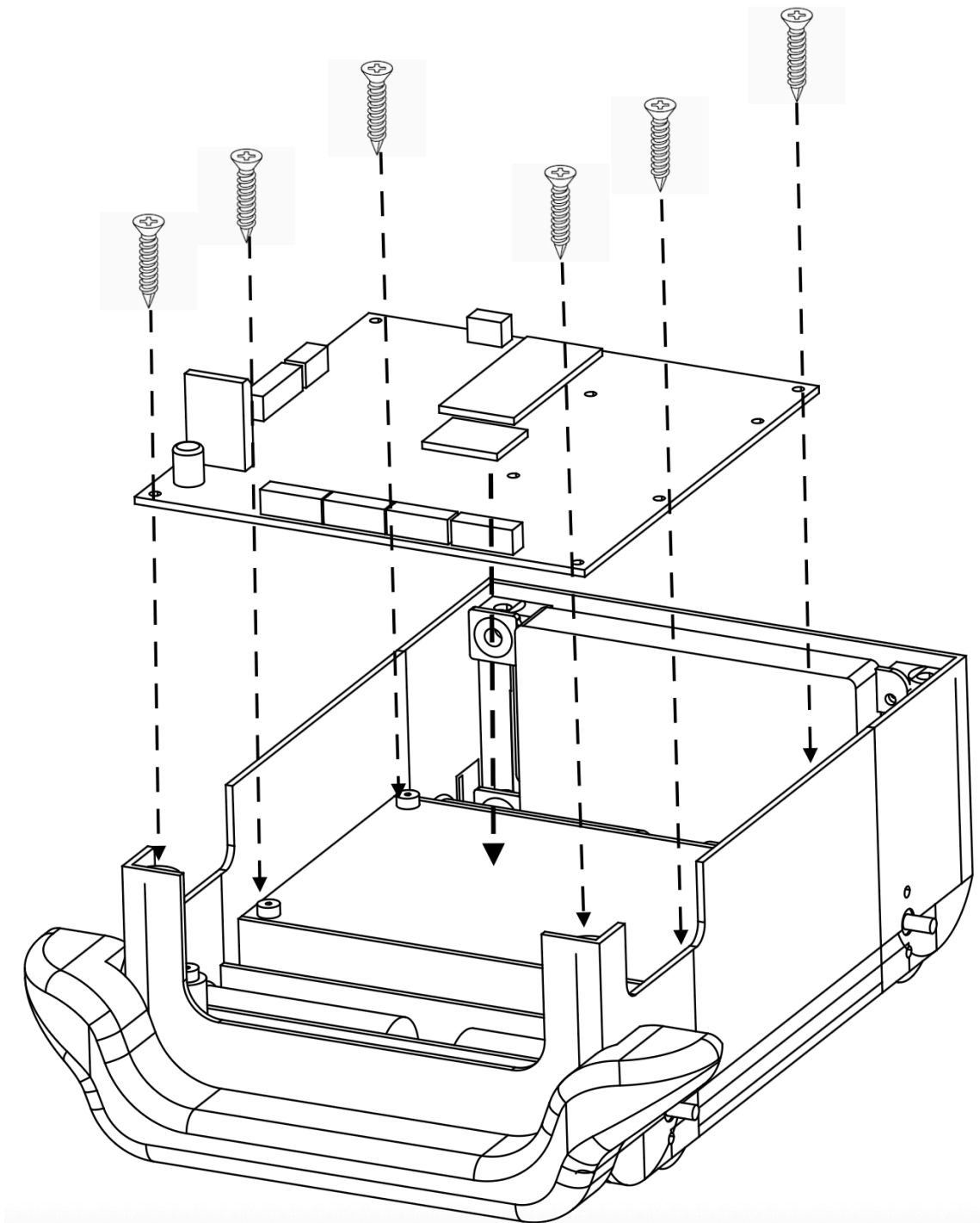



3.8 Install Lidar into O2D R5 Cover

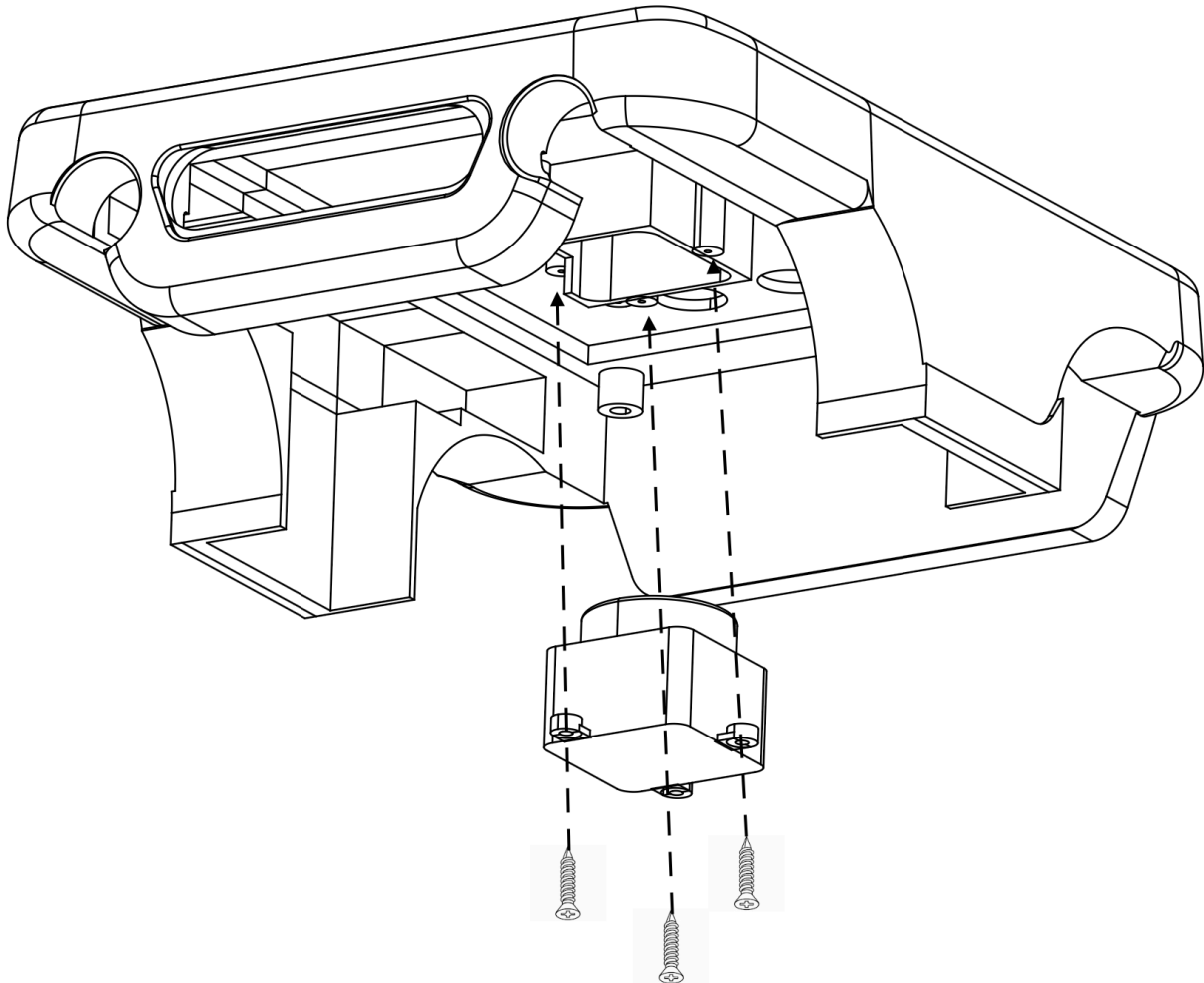



3.9 Install Lidar Communication Module into PT5 Cover

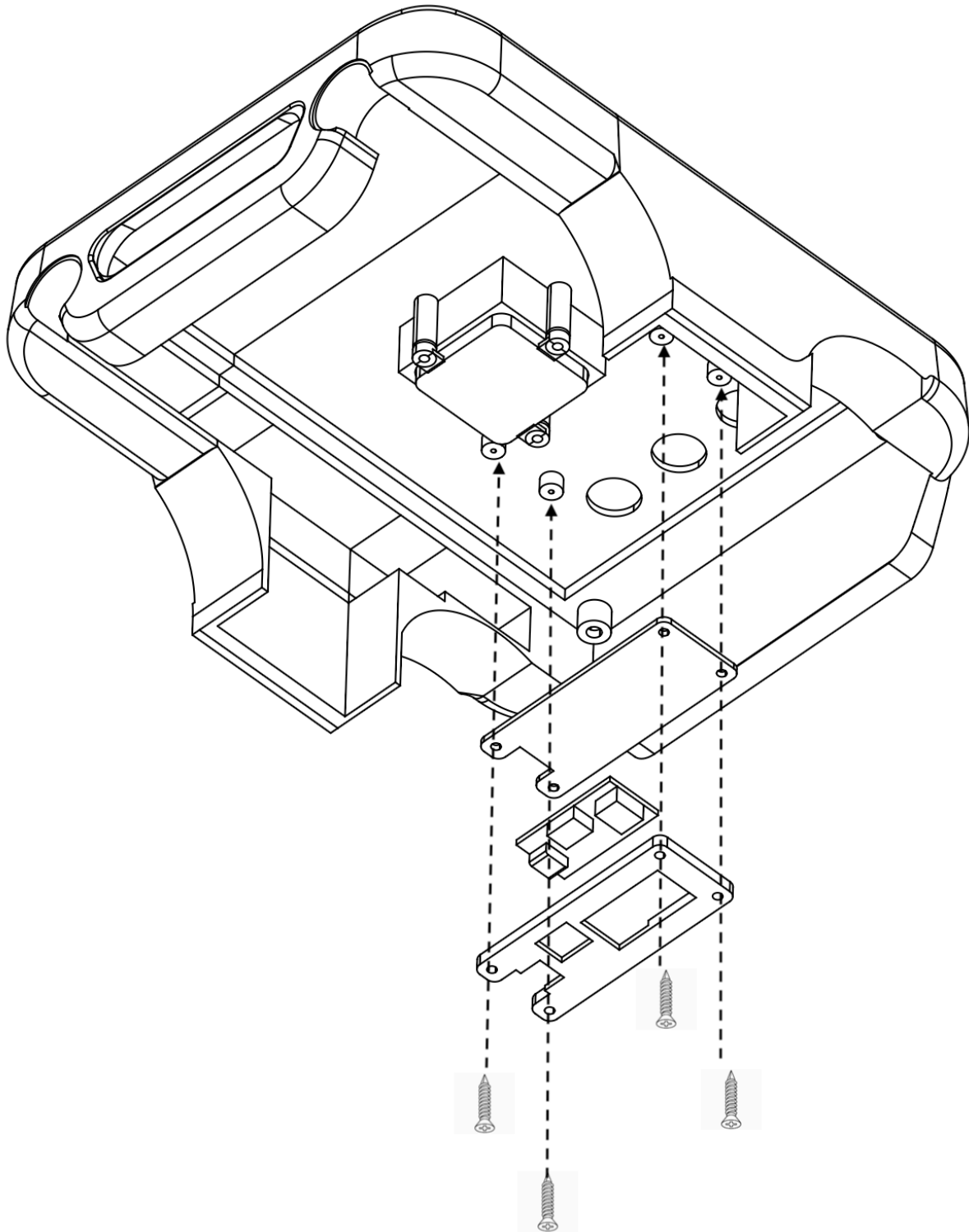



3.10 Install the LED lens and the LEDs into O2D R5 Cover

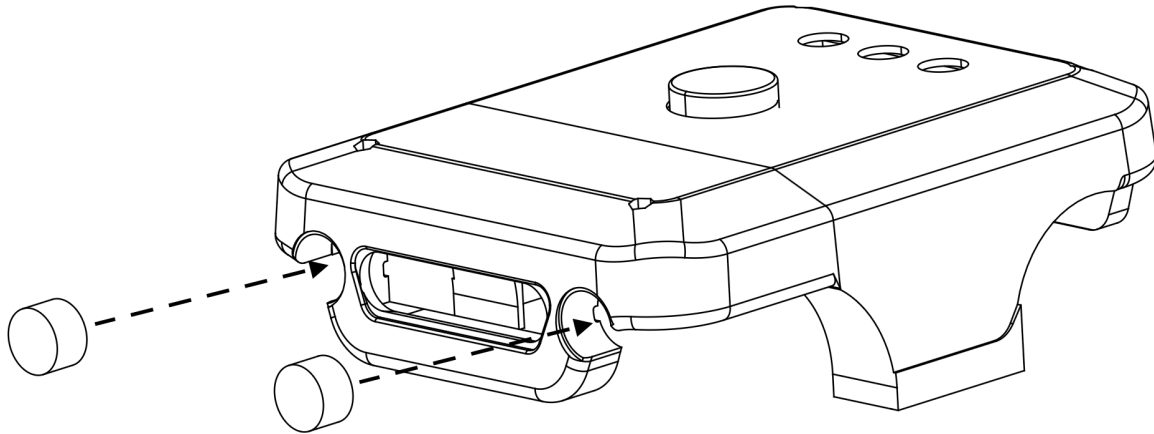

* Apply glue to the contact surfaces before mounting.

3.11 Install Switch Button and Push Buttons into O2D R5 Cover

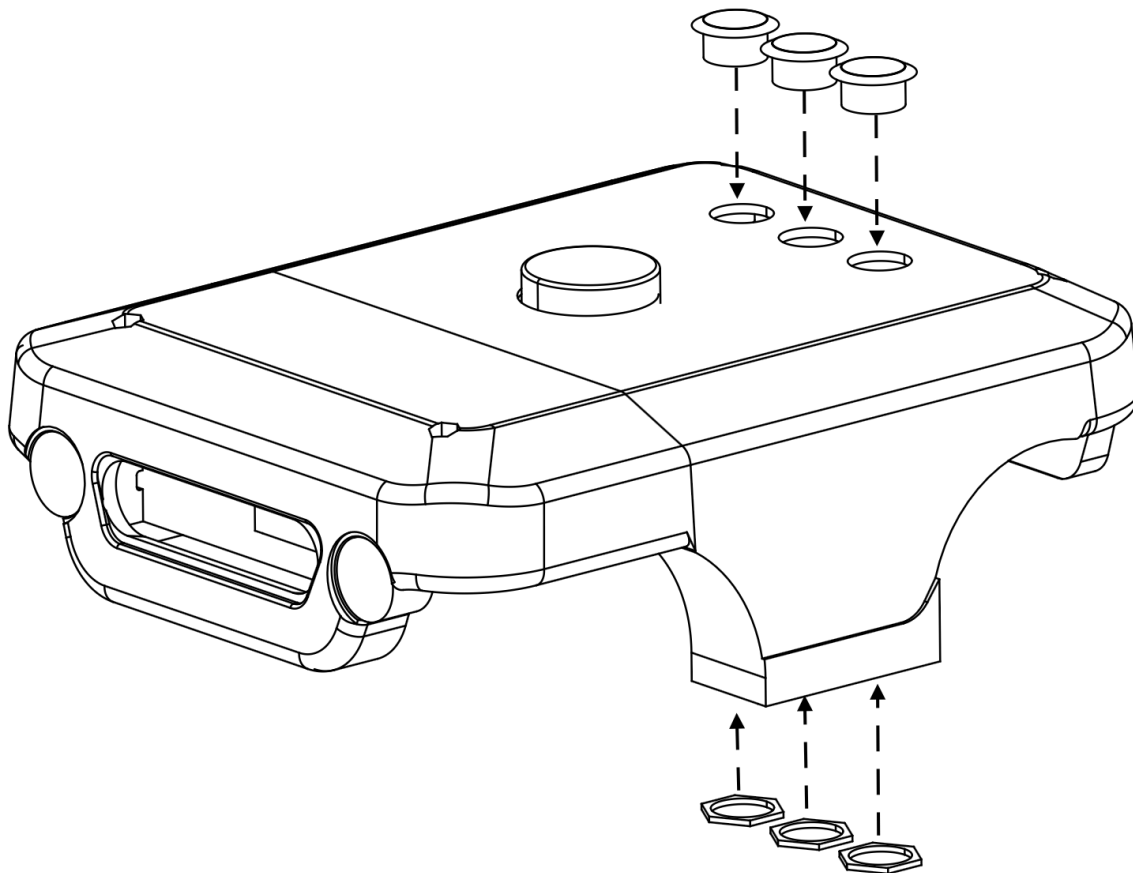



3.12 Install the Depth Camera into O2D R5 Cover

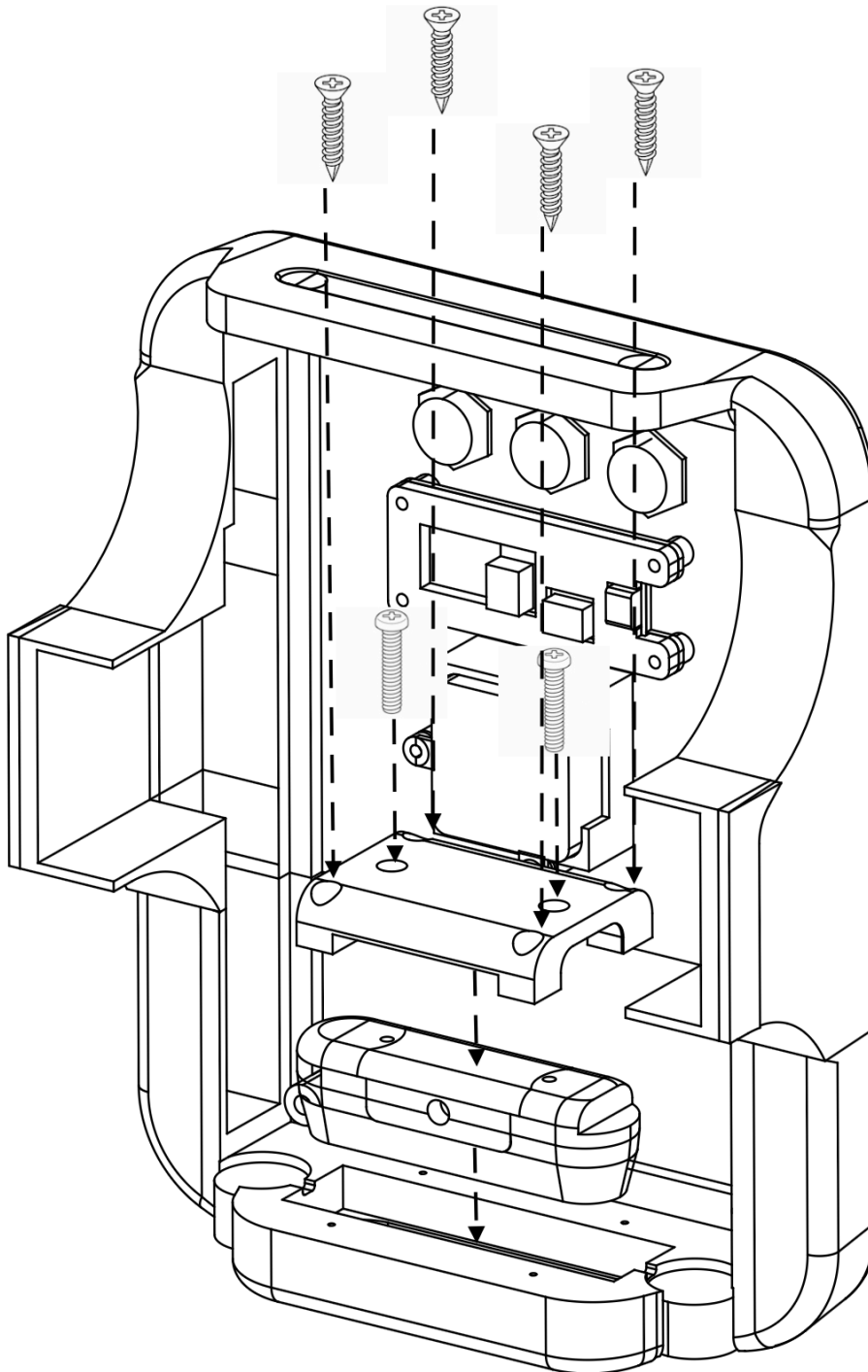

* After this step the wiring and installation of the Main Board and it's child elements must be done (Steps 4.2 - 4.20).



3.13 Install M4x12 Nuts into O2D R5 Cover

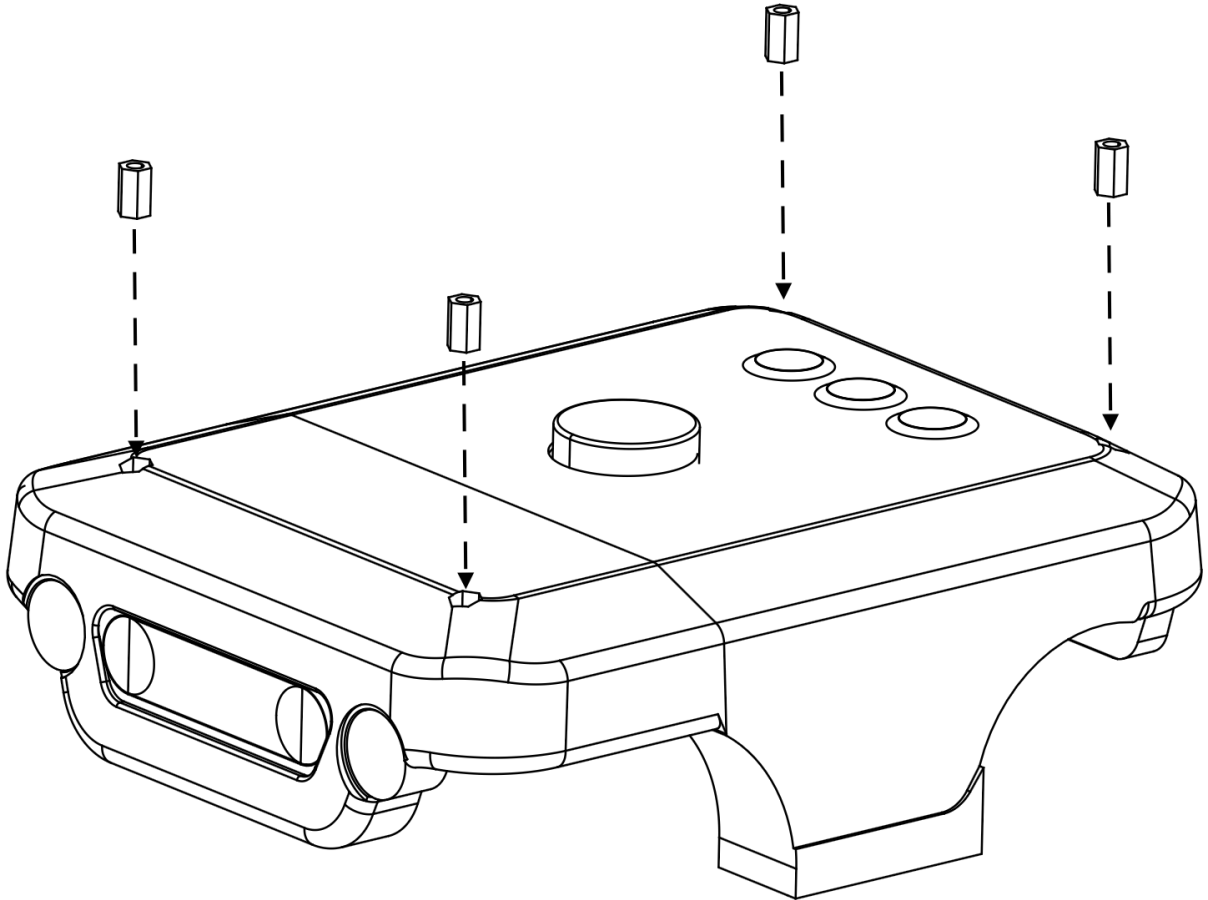



3.14 Mount O2D R5 Cover on O2D R5 Body

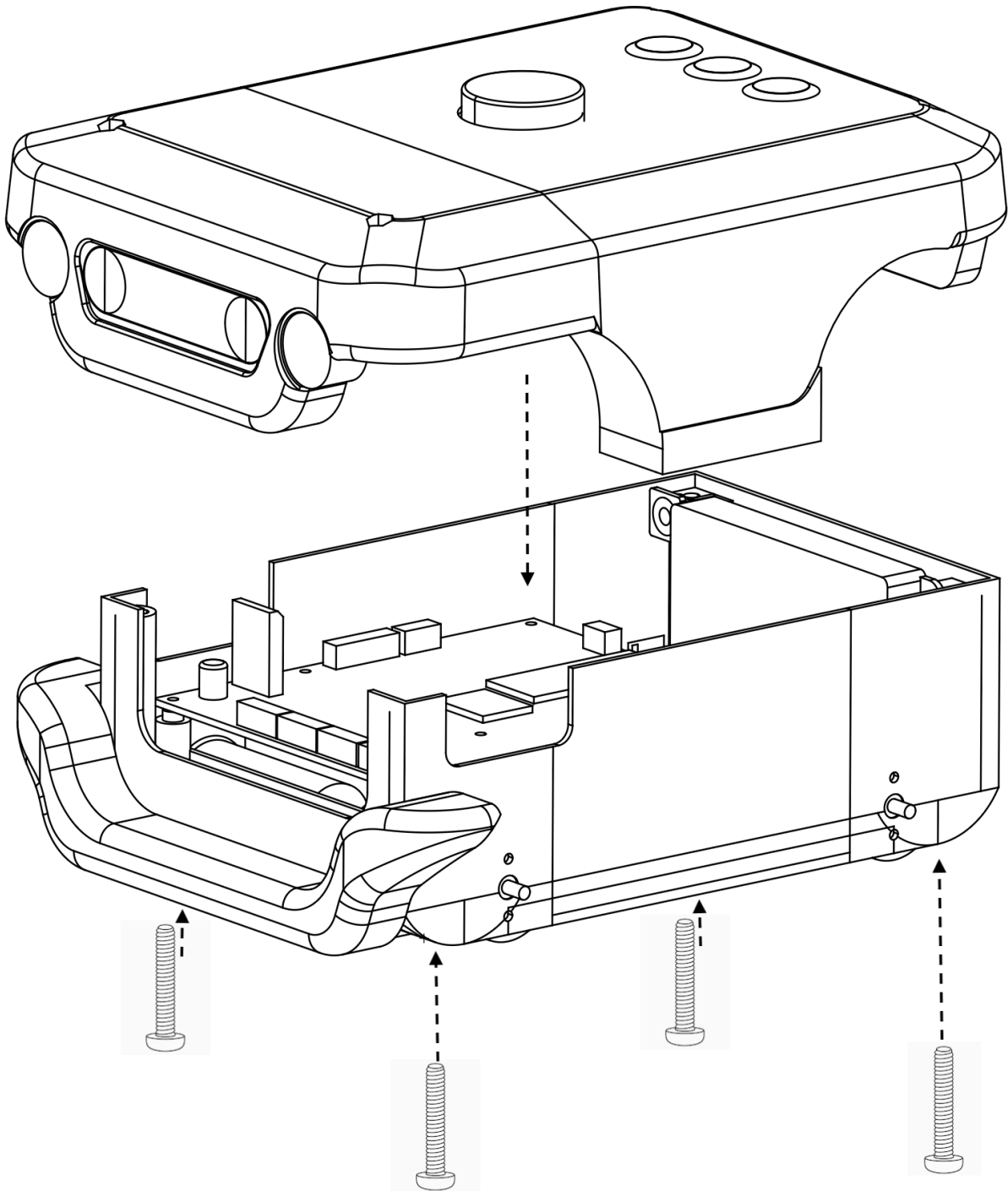



3.15 Mount Wheels

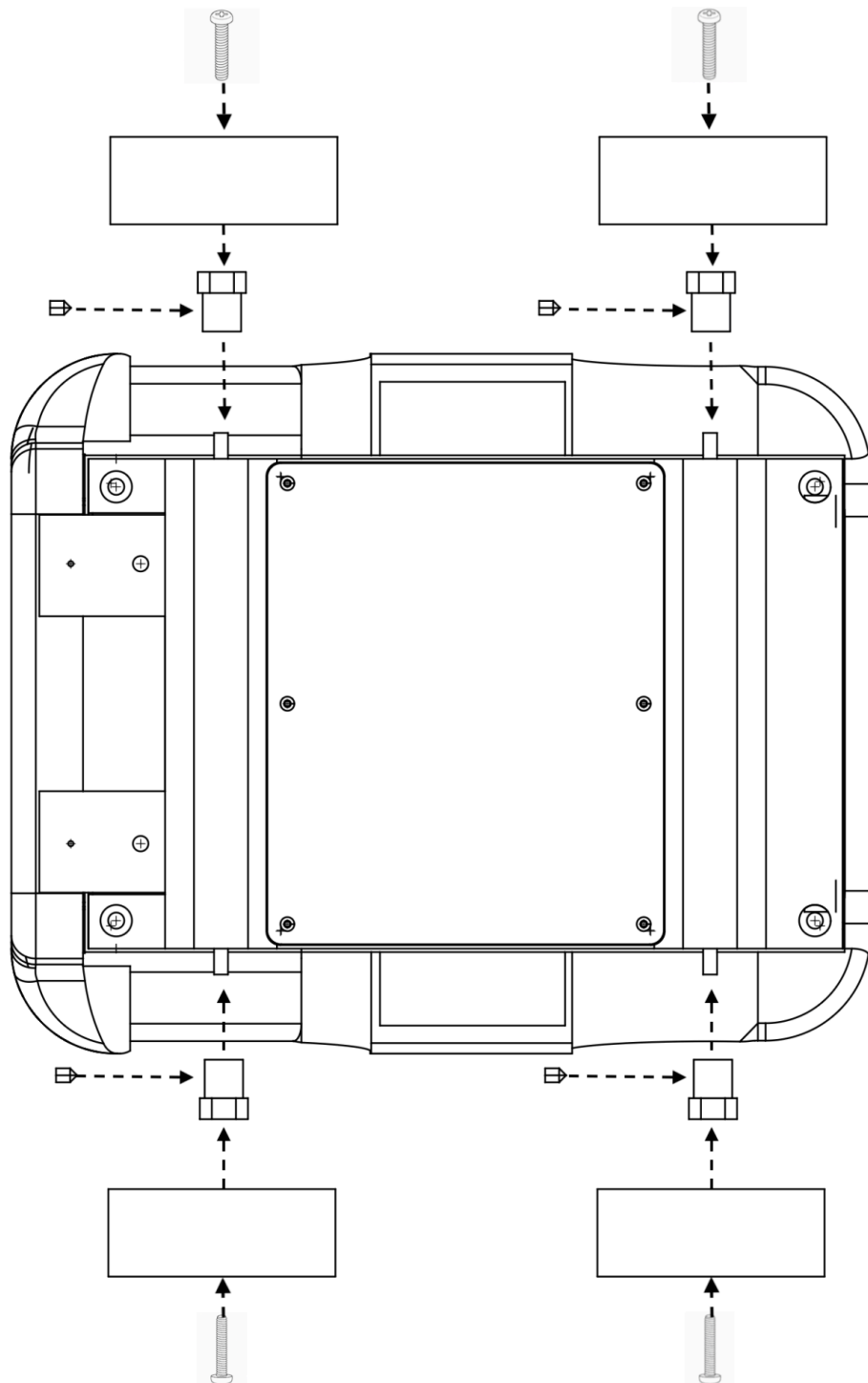



4. Electronics Assembly

4.1 Assemble the battery

Right after the assembly - install it into the battery compartment and mount the battery compartment lid (step 3.3).

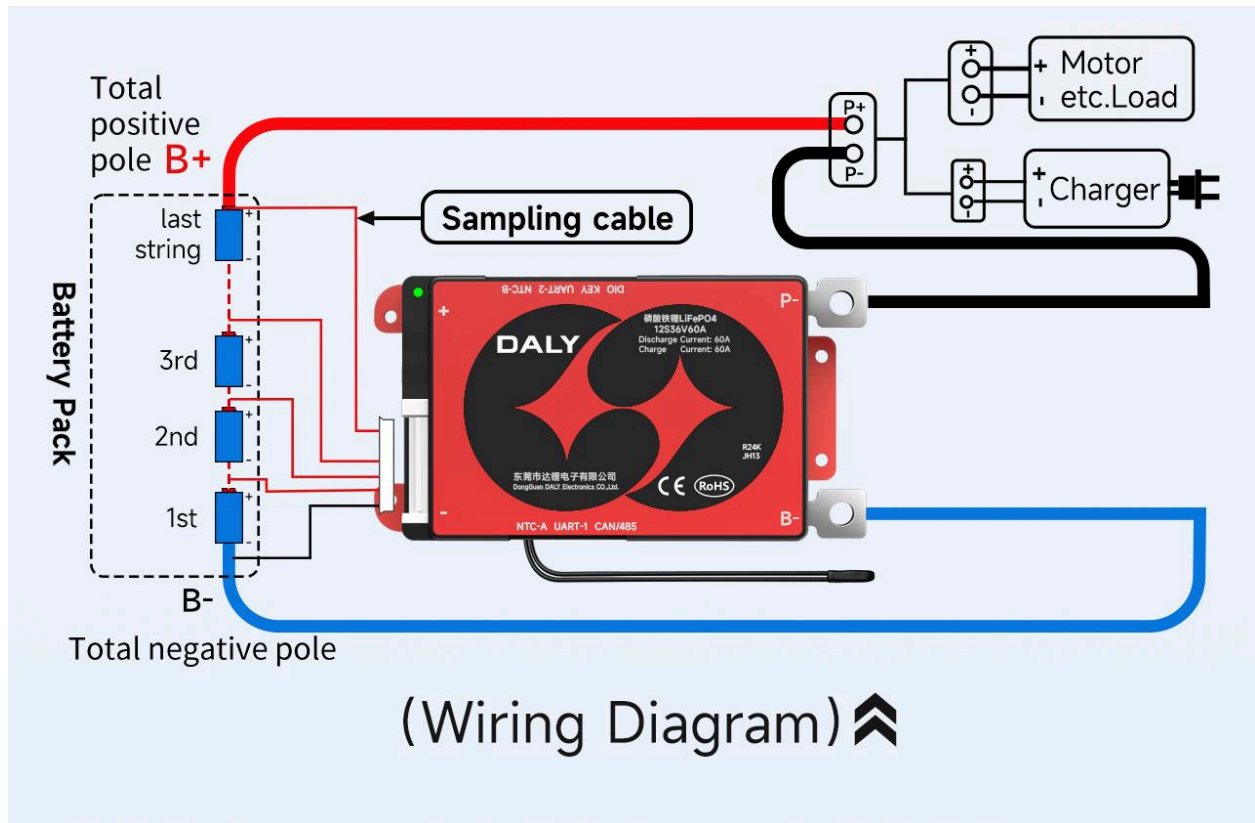

The output of the battery compartment must be the Sampling cable, B + and B- wires.



4.2 Install RP2040 into the Main Board

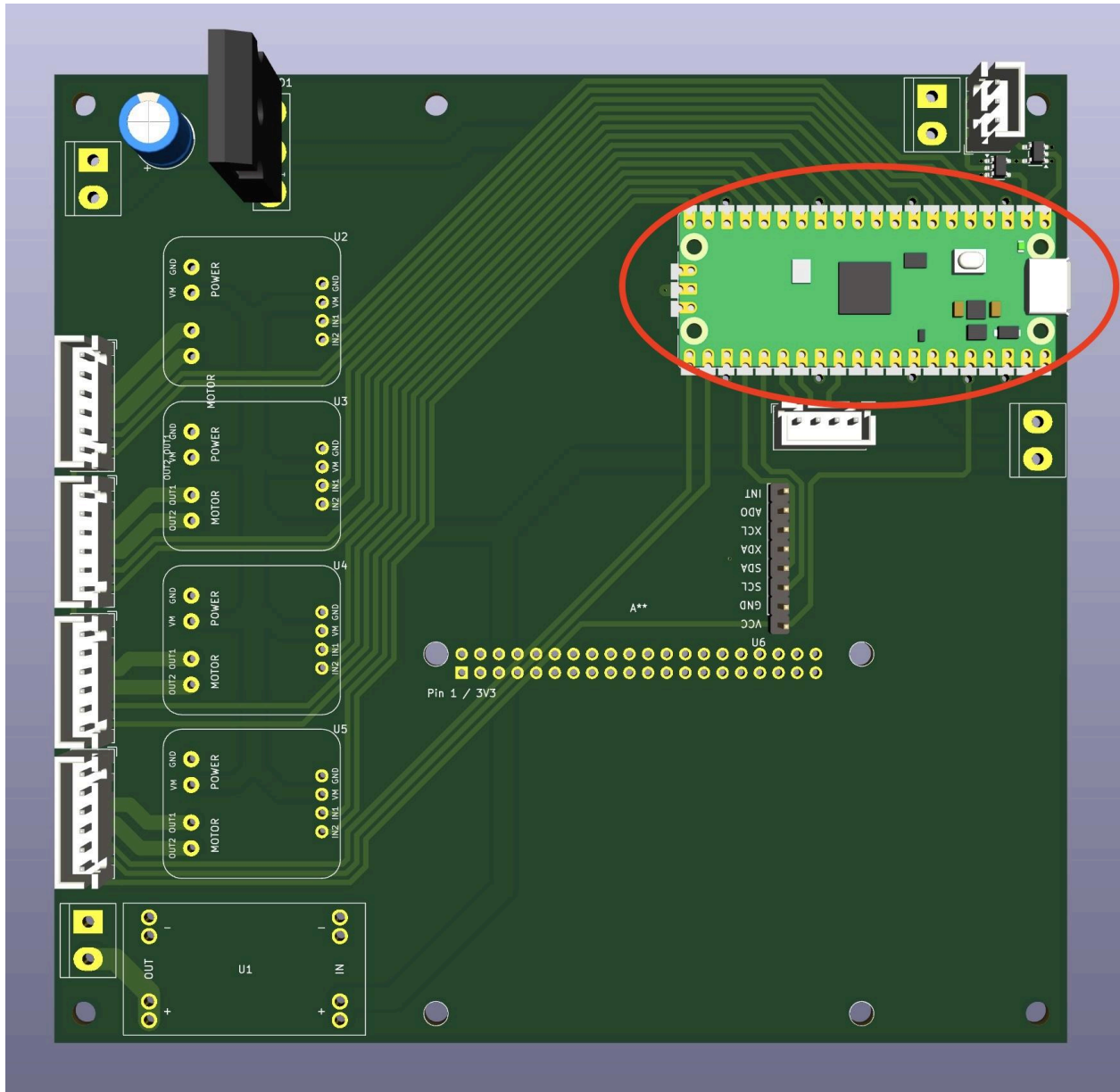



4.3 Install GY-521 IMU module into the Main Board

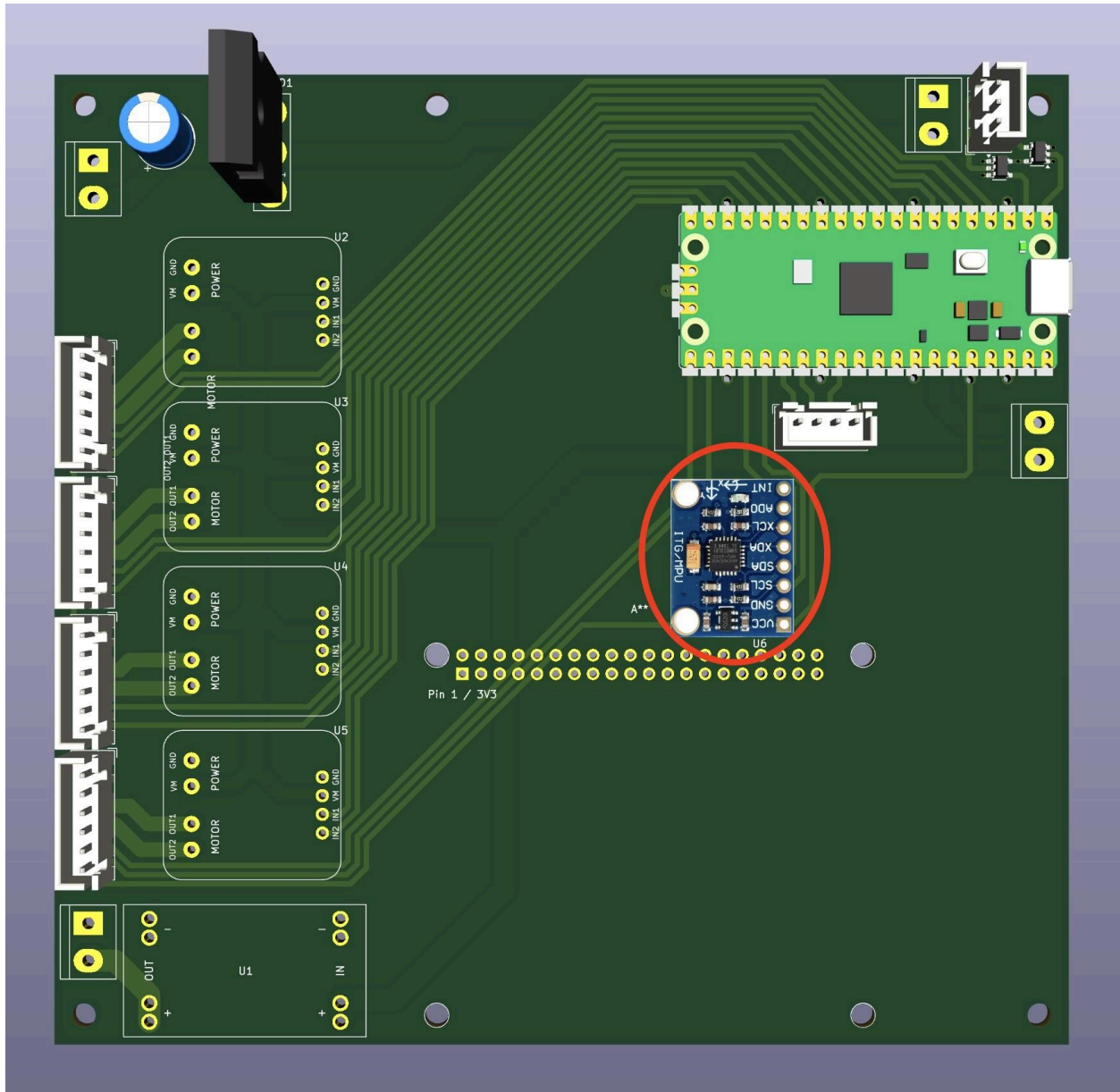



4.5 Install Mini560 5V 5A Step Down DC-DC Converter into the MainBoard

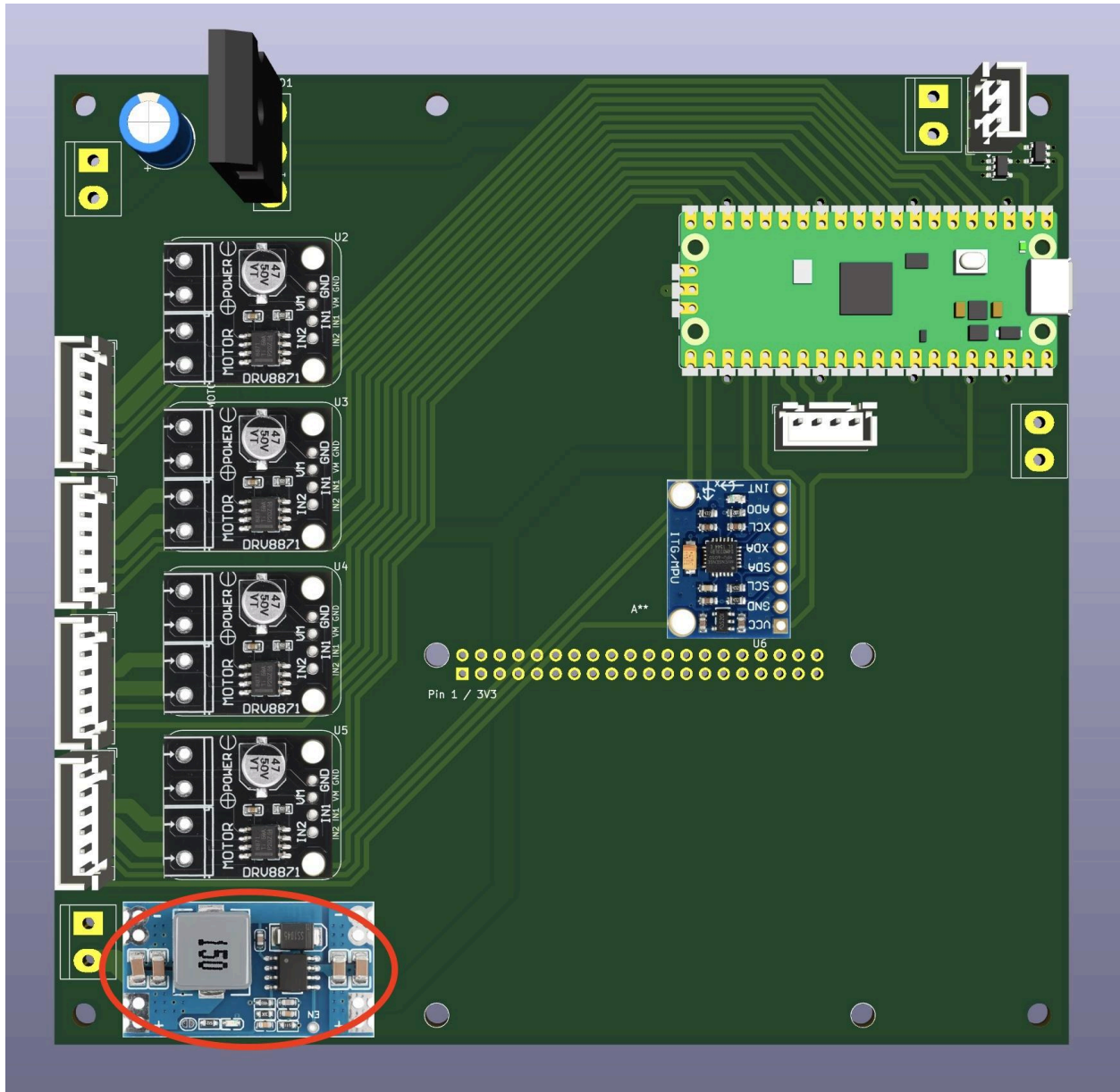



4.6 Install Raspberry Pi 5 into the Main Board

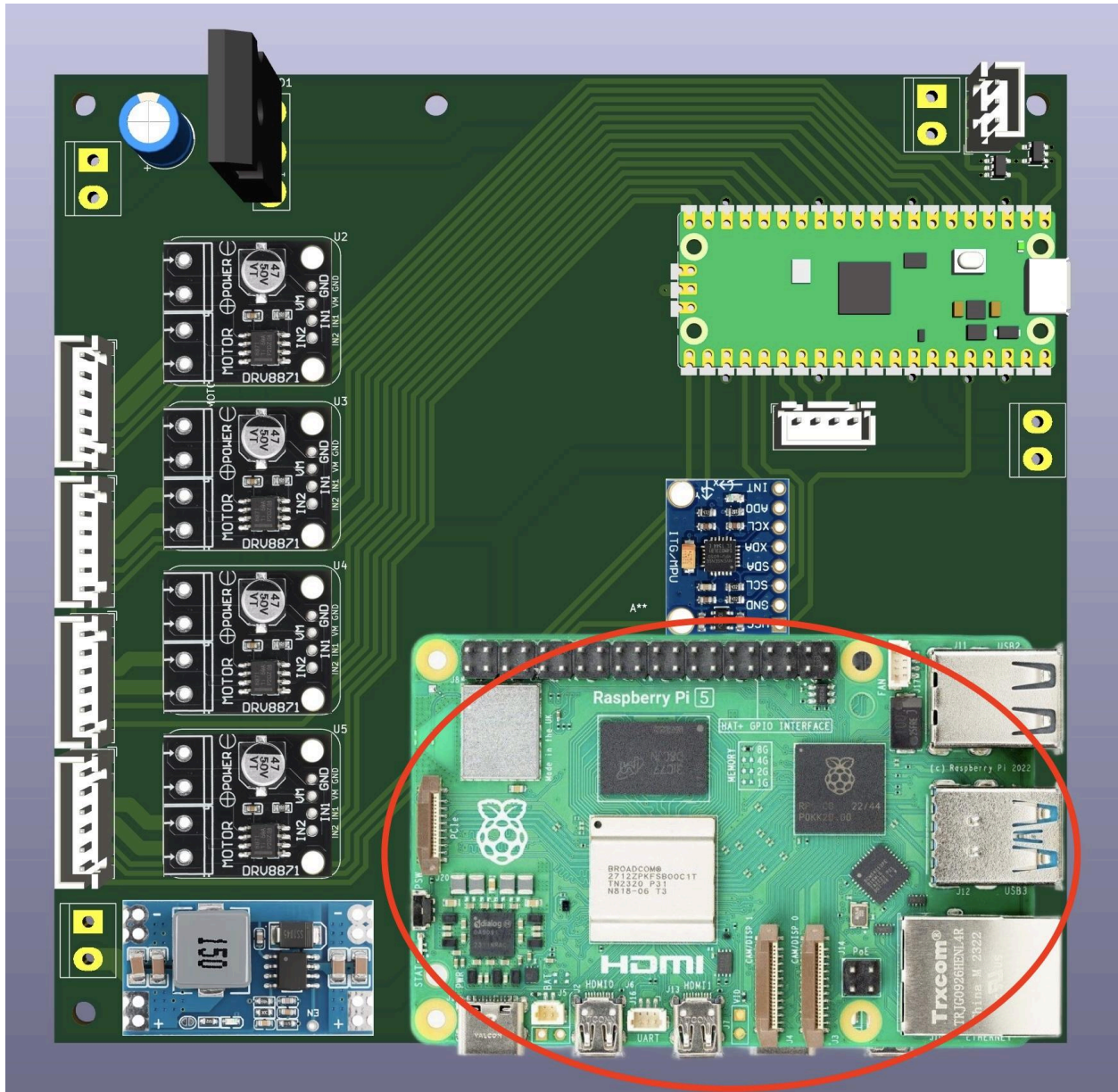



4.7 Connect the battery sampling cable to BMS

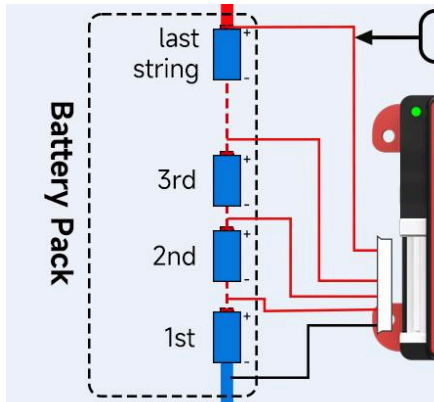

4.8 Connect the negative contact of the battery pack to B- contact of BMS





4.9 Connect P- contact of BMS to the Main Board “P-” Terminal

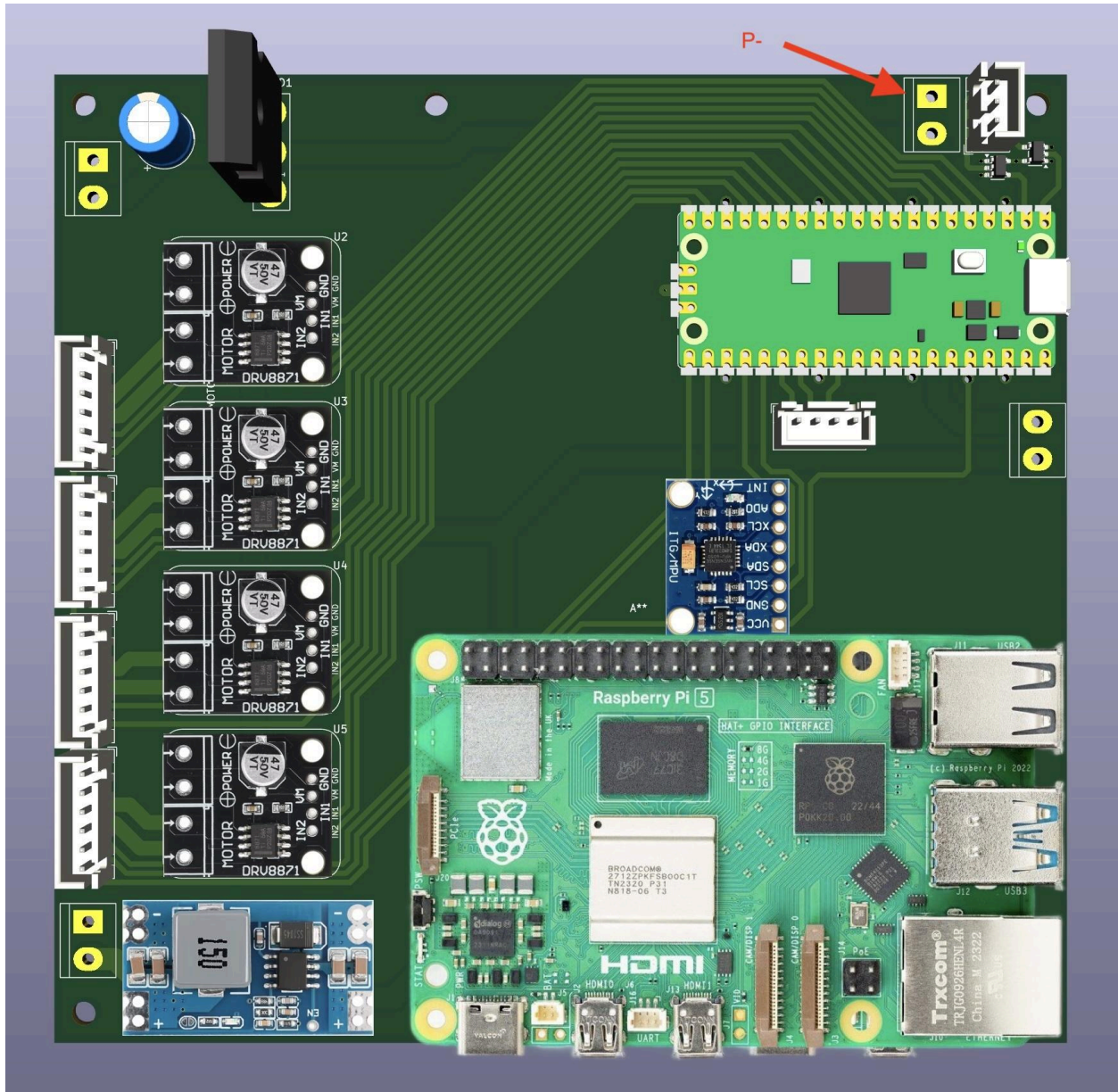



4.10 Connect Battery + Wire to the Main Board “Battery +” Terminal

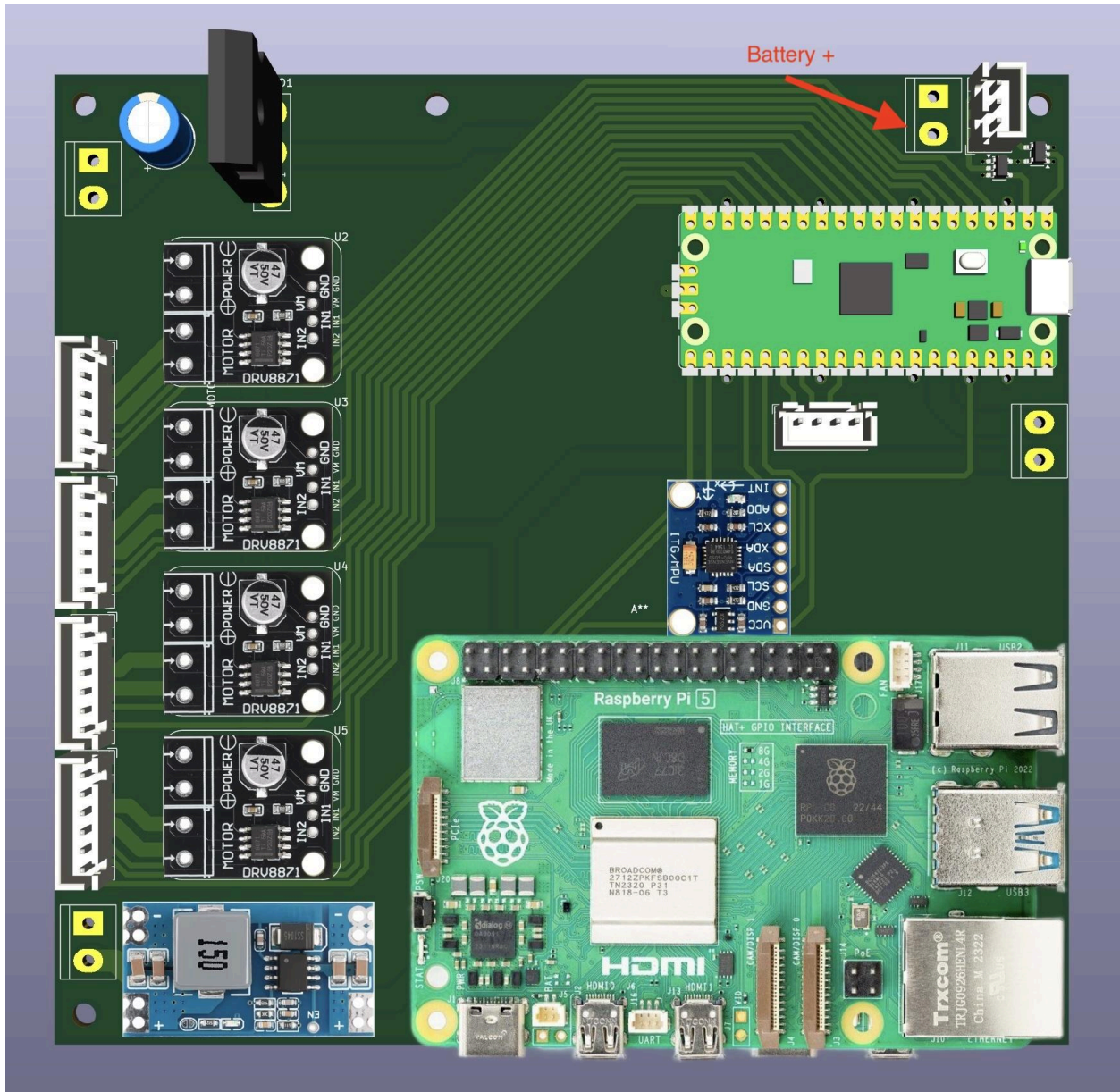



4.11 Connect Charger + and Charger - Plate wires to the MainBoard Charger terminal

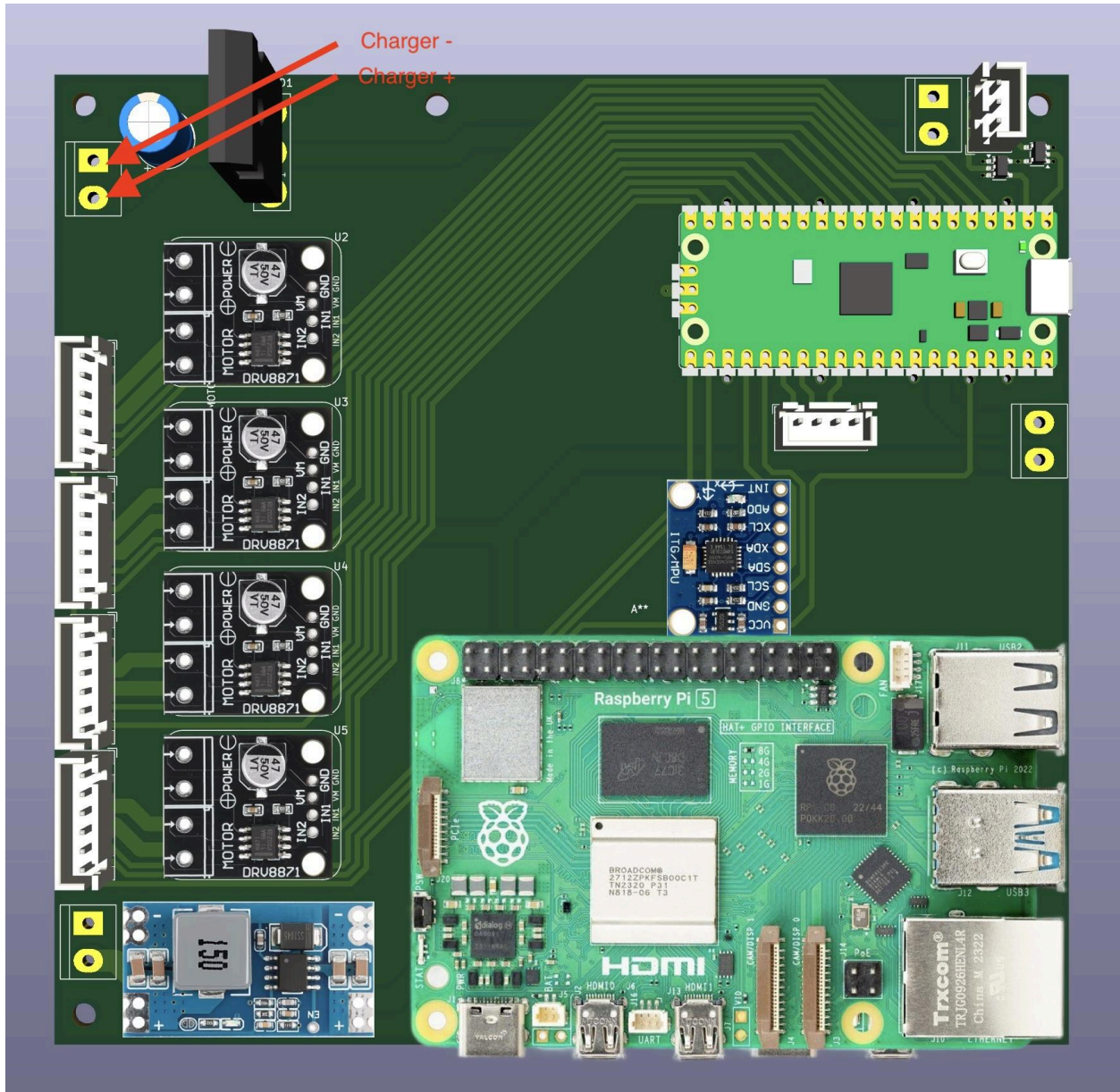



4.12 Connect Daly BMS UART port to BMS UART port of the MainBoard

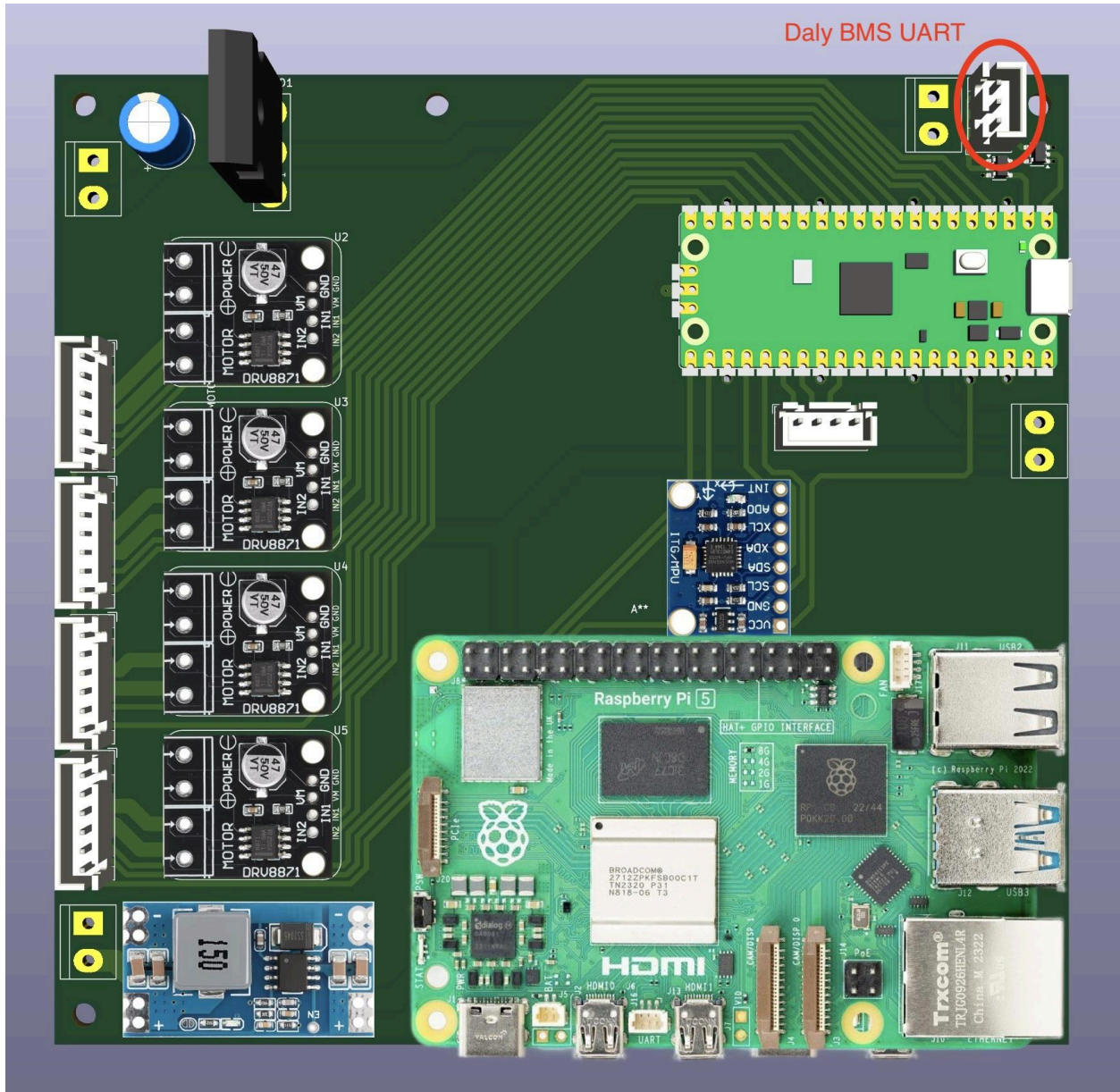



4.13 Connect On/Off Switch to On/Off Terminal of the MainBoard

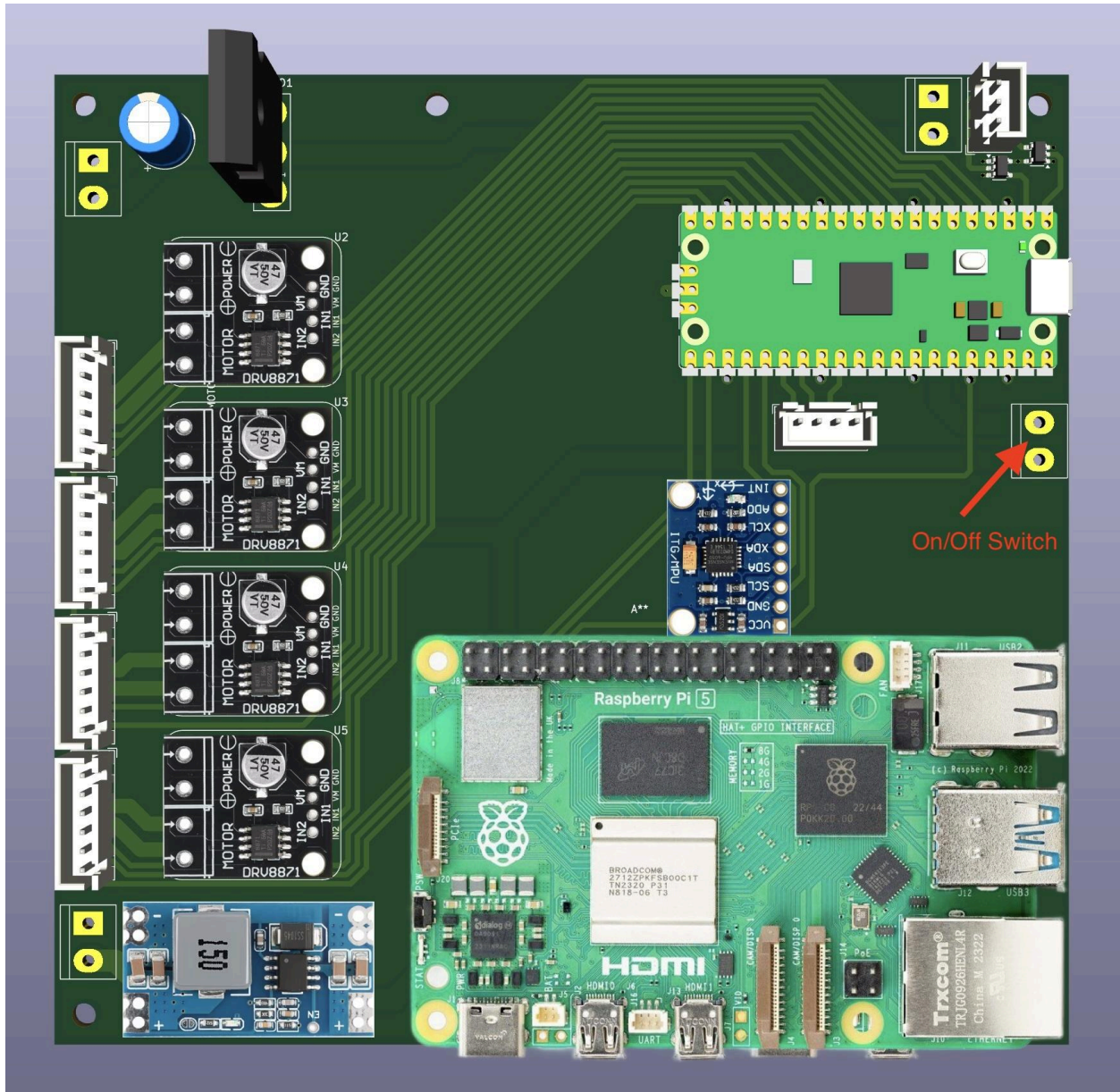



4.14 Connect Functional Buttons and LEDs to the peripheral terminal of the Main Board

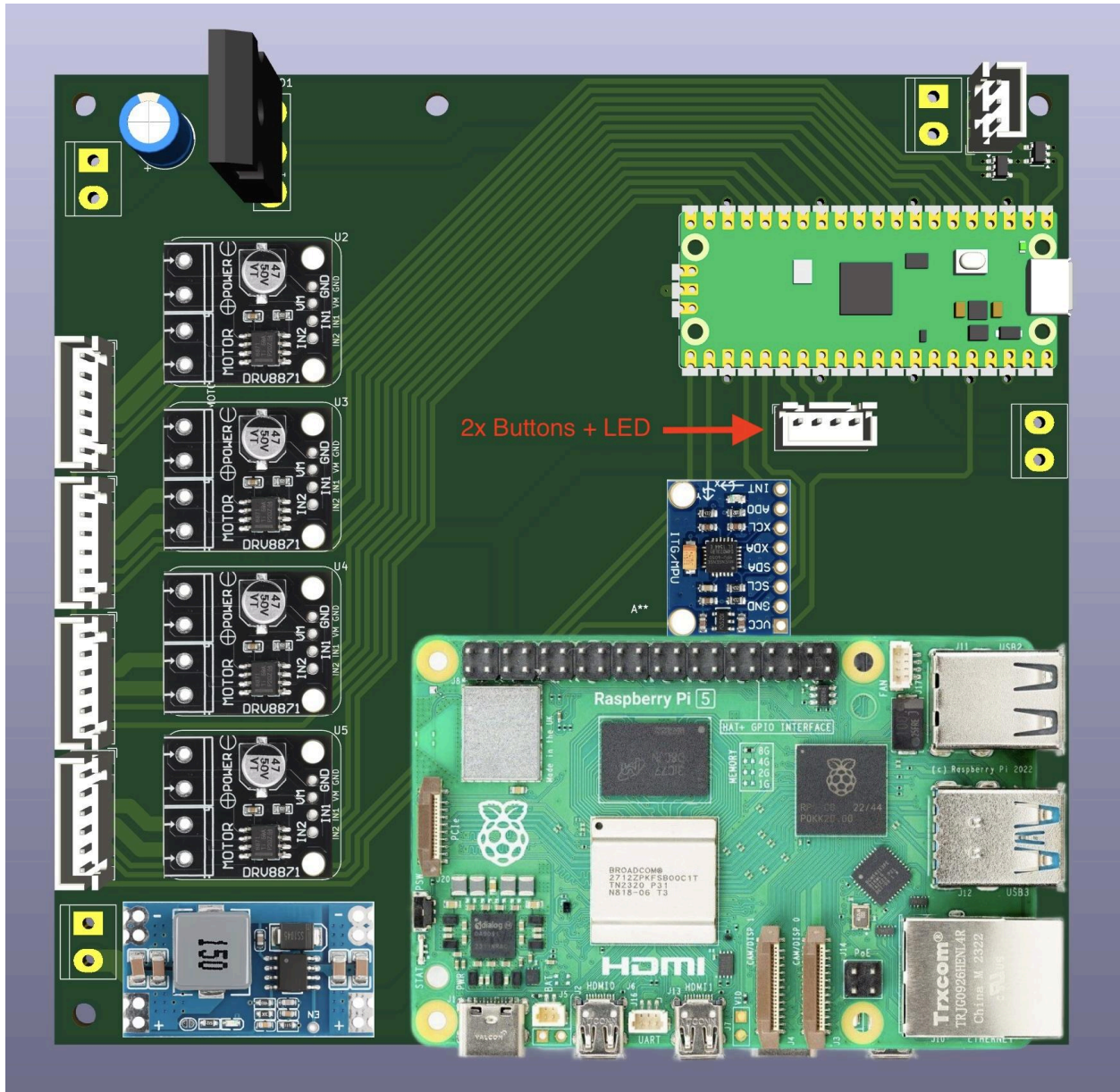



4.15 Connect Raspberry Pi 5 to 5V 5A terminal of the MainBoard.

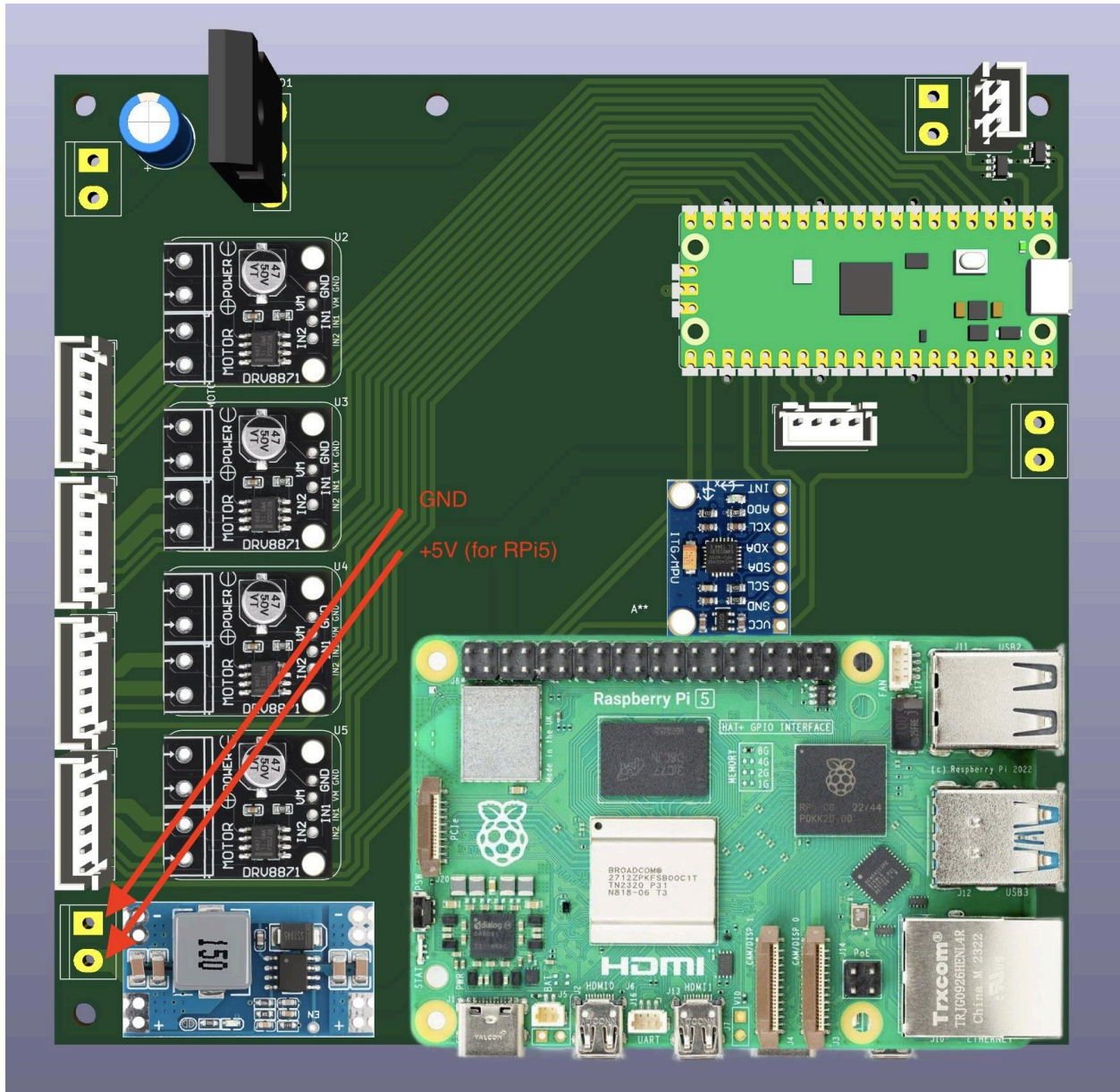

* Use the modified USB Type-C cable with the power wires suitable for the terminal



4.16 Connect the motors to the Main Board

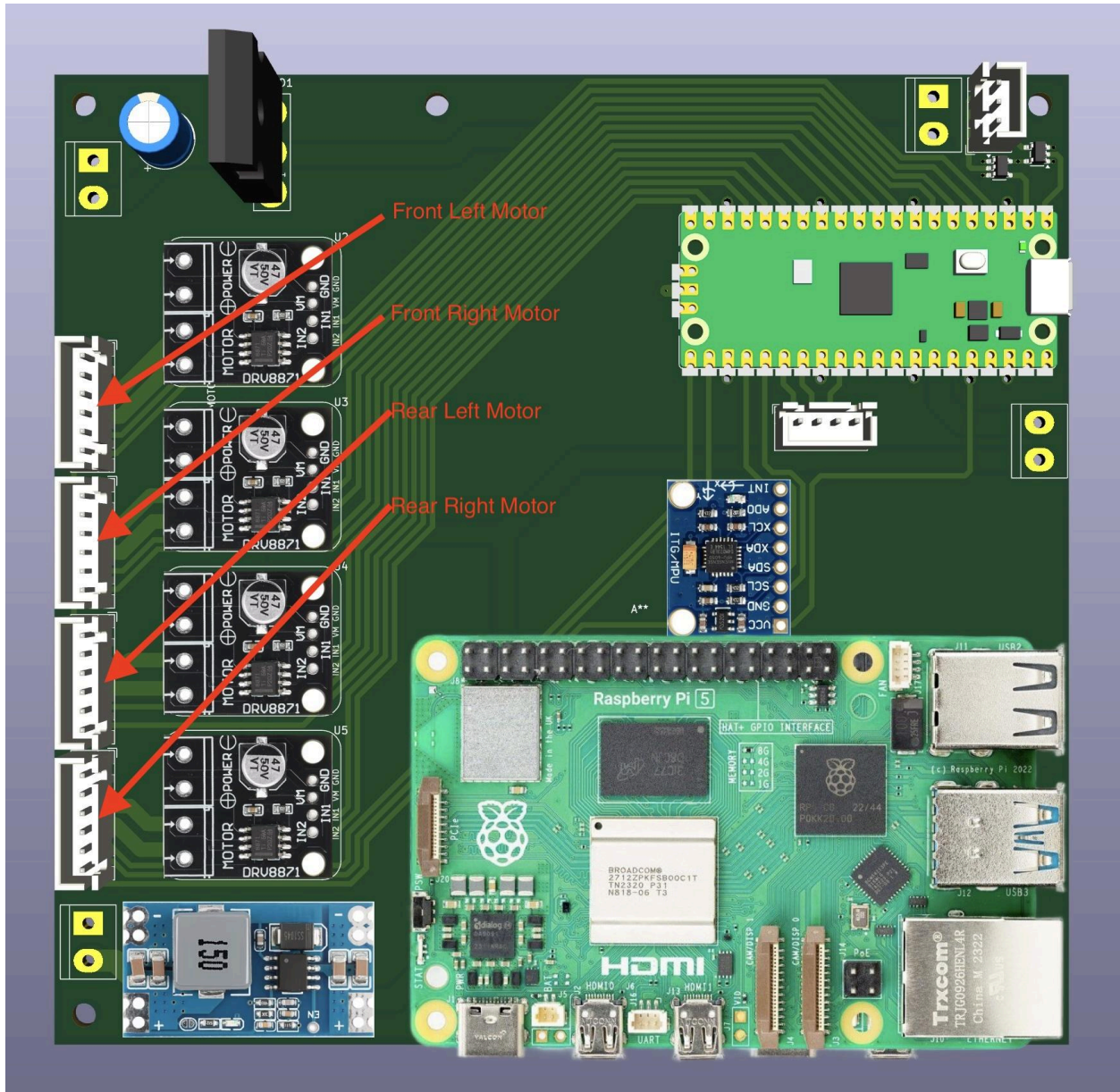



4.17 Review the Main Board Wiring

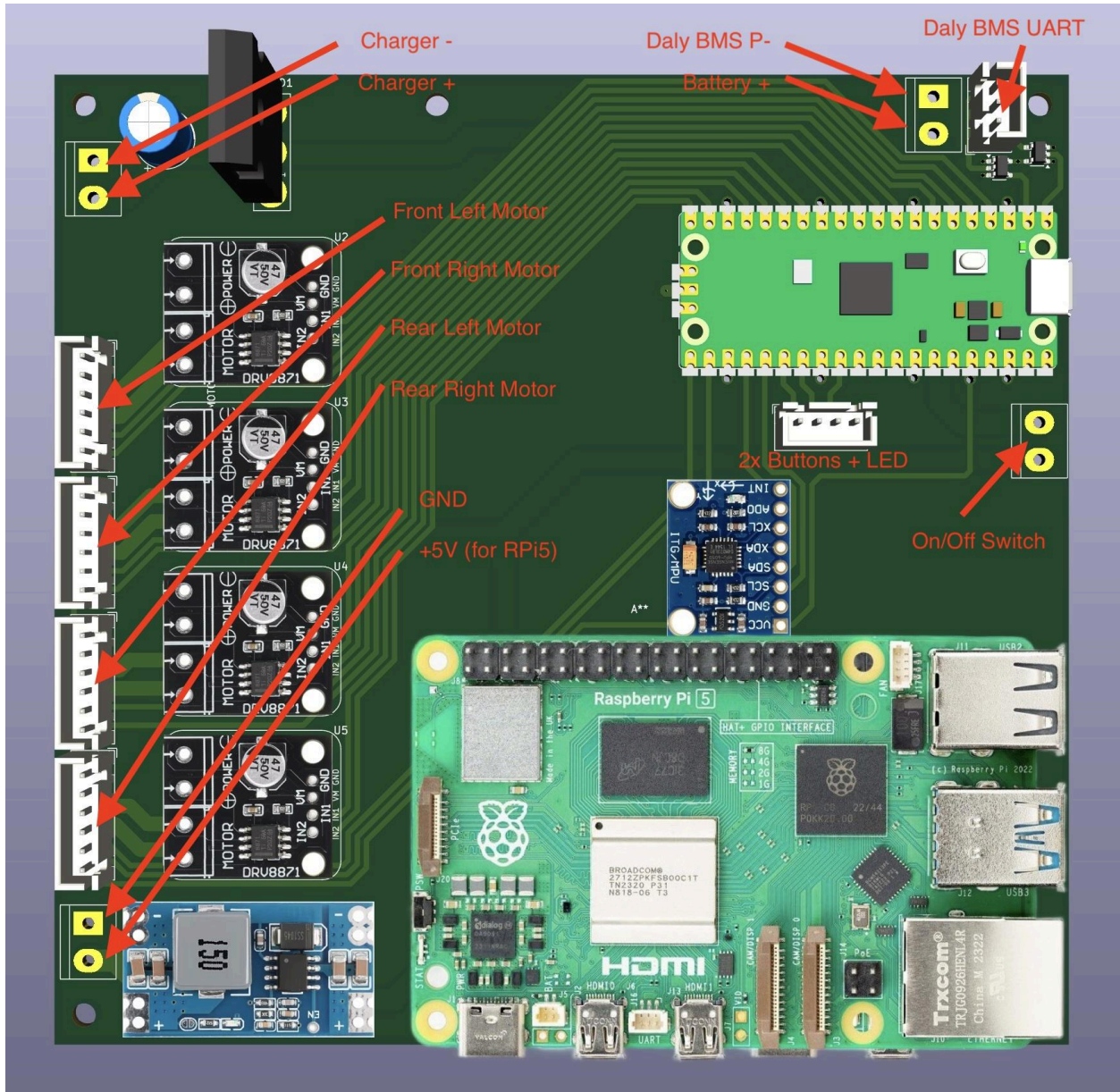



4.18 Connect the Depth Camera to the Raspberry Pi with USB Type-C Cable

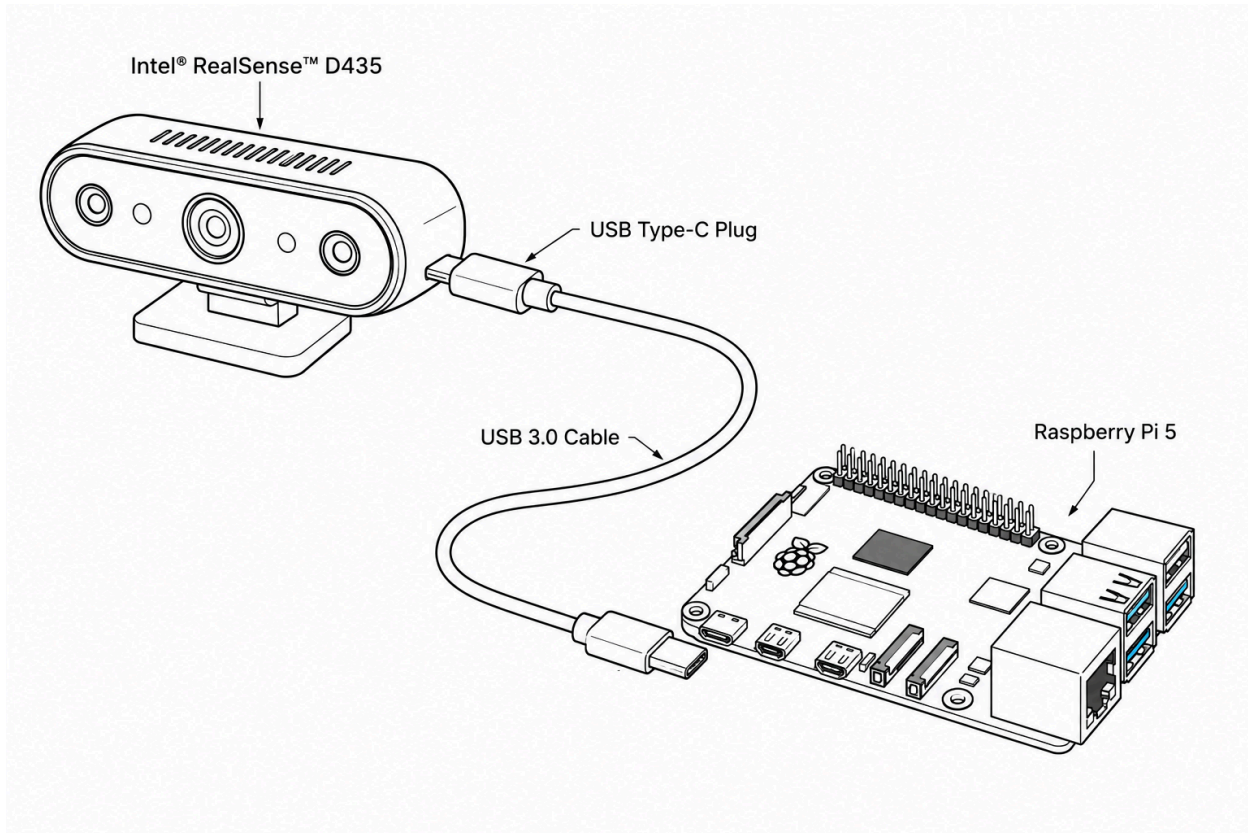



4.19 Connect D500 Lidar Communication Module to the Raspberry Pi with USB Type-C Cable

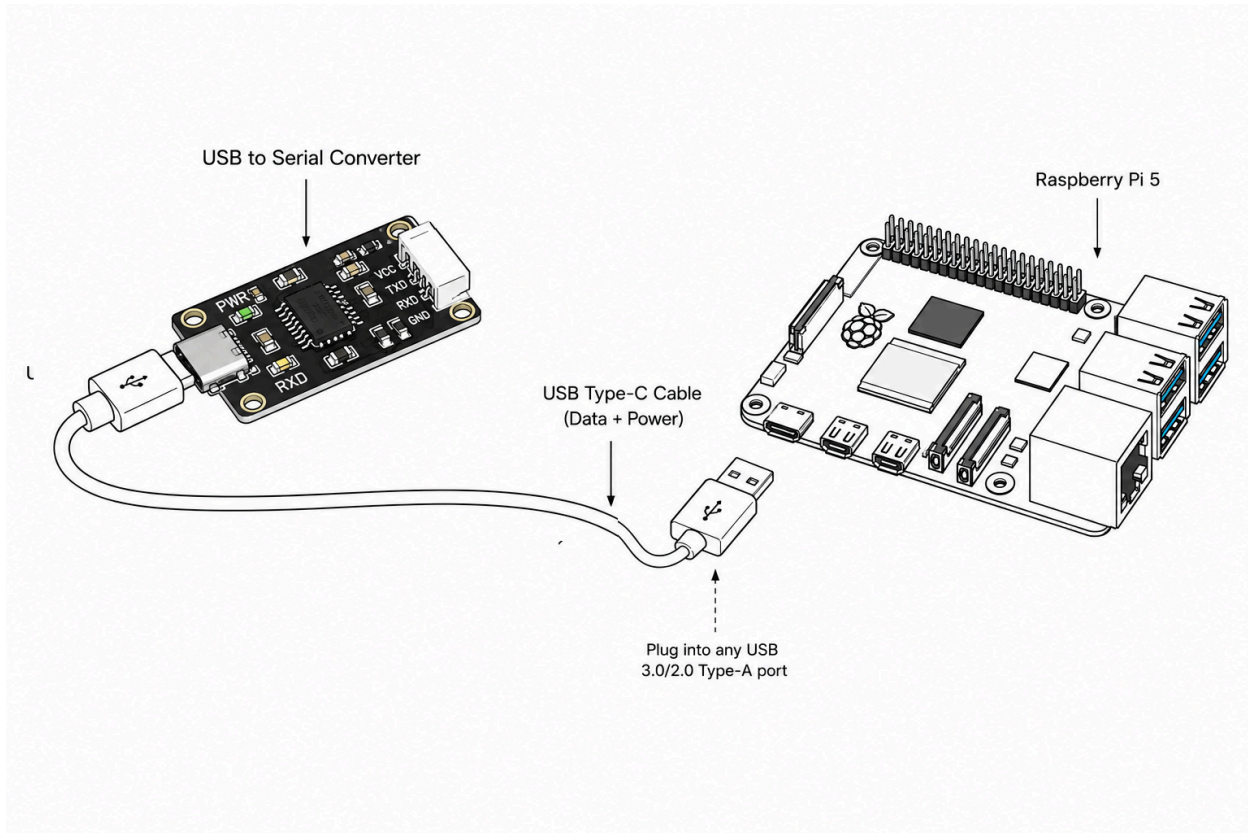



4.20 Raspberry Pi Pico RP2040 to the Raspberry Pi with USB Type-C Cable

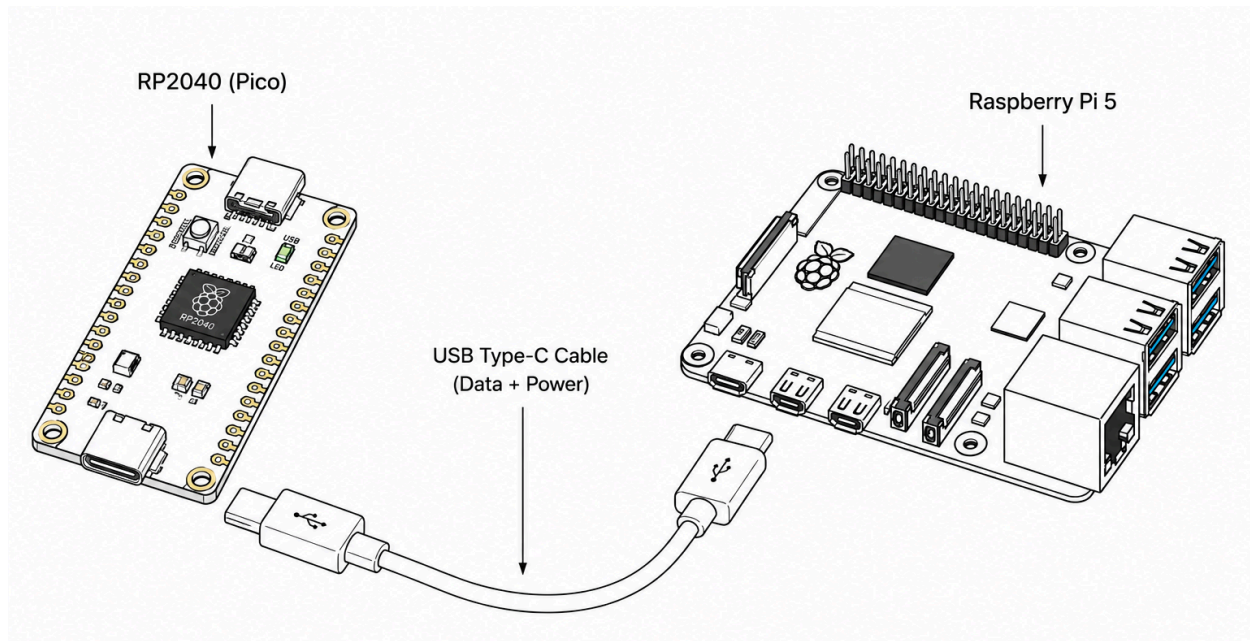

5. Software Installation

5.1 Download Ubuntu 24.04 Server image install it through Balena Etcher on USB flash drive

The image can be downloaded here:

<https://cdimage.ubuntu.com/releases/24.04/release/>

5.1 Insert the USB Flash Drive into Raspberry Pi5, and run Ubuntu 24.04 installation process

5.2 Install Docker dependencies

```
sudo apt update
sudo apt install -y ca-certificates curl gnupg
sudo install -m 0755 -d /etc/apt/keyrings
curl -fsSL https://download.docker.com/linux/ubuntu/gpg | sudo gpg
--dearmor -o /etc/apt/keyrings/docker.gpg
echo \
```



```
"deb [arch=$(dpkg --print-architecture)
signed-by=/etc/apt/keyrings/docker.gpg]
https://download.docker.com/linux/ubuntu \\\n $(. /etc/os-release &&
echo $VERSION_CODENAME) stable" | \
sudo tee /etc/apt/sources.list.d/docker.list > /dev/null
sudo apt update
sudo apt install -y docker-ce docker-ce-cli containerd.io
docker-buildx-plugin docker-compose-plugin
```

5.3 Configure Docker User Access Rights

```
sudo usermod -aG docker $USER
sudo usermod -aG dialout $USER # To allow to access the serial ports
```

5.4 Create Docker files for ORB container

Create `docker-compose.yml`:

```
version: '3.8'
services:
  o2d:
    image: telemetrybalkan/o2d:latest
    devices:
      - "/dev:/dev"
    group_add:
      - 20
    environment:
      - RMW_IMPLEMENTATION=rmw_fastrtps_cpp
    privileged: true
    network_mode: host
    stdin_open: true
    tty: true
    volumes:
      - o2d_volume:/ws
volumes:
  o2d_volume:
```



5.5 Launch Docker Container

5.5.1 Launch the Container

```
docker compose -f docker-compose.yml up -d
```

5.5.2 Check the Container Status

```
docker compose ps
```

5.6 Confirm the software is running

Open the browser with the IP address of your raspberry pi. Port 80. You must see the Web UI of ORB Robot Control Software:

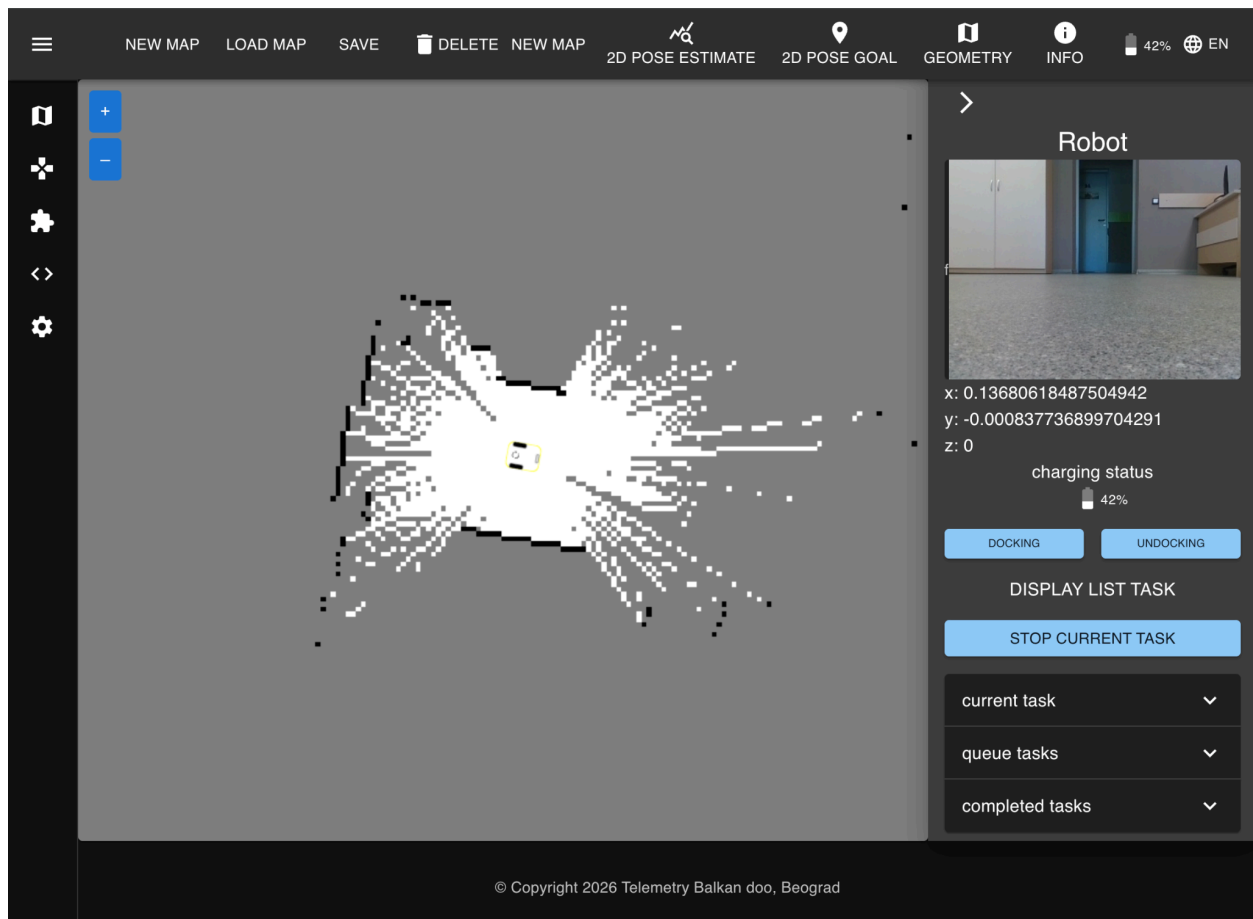



6. Limitation of Liability

The O2D R5 robotic platform is intended for research, educational, development, and experimental purposes. The assembly, operation, modification, and use of the robot described in this manual are performed entirely at the user's own risk.

Telemetry Balkan doo Beograd, its employees, contributors, and affiliates shall not be held liable for any direct, indirect, incidental, consequential, or special damages arising from:

- Improper assembly or installation
- Incorrect electrical wiring or battery handling
- Use of incompatible components or accessories
- Software misconfiguration or unauthorized software modifications
- Mechanical failures or component defects caused by misuse
- Damage to property, equipment, or connected systems
- Personal injury resulting from operation, maintenance, or testing of the robot
- Loss of data, operational downtime, or business interruption

Users are solely responsible for:

- Verifying the correctness of all electrical connections before powering the system
- Ensuring safe handling and charging of LiFePO4 batteries
- Operating the robot in a controlled and safe environment
- Complying with all applicable local laws, regulations, and safety requirements
- Performing adequate testing before autonomous or unattended operation

The O2D R5 contains moving mechanical components, electrical circuits, lithium-based energy storage systems, and autonomous software systems that may present risks if improperly assembled or operated. Appropriate protective measures and engineering practices must always be followed.

Telemetry Balkan doo Beograd provides this documentation and the associated hardware and software “as is” without warranties of any kind, either expressed or implied, including but not limited to warranties of merchantability, fitness for a particular purpose, and non-infringement.

Users are encouraged to regularly inspect the robot for damaged wiring, loose mechanical parts, overheating components, battery abnormalities, or software malfunctions prior to operation.

7. Support

Telemetry Balkan doo Beograd is committed to supporting the O2D R5 robotics platform and its user community.



Users can contact the Telemetry Balkan technical team for questions related to assembly, software setup, hardware integration, and general operation of the O2D R5 platform by emailing:

support@telemetrybalkan.com

The technical team will respond to community-originated questions on a best-effort basis. Response times may vary depending on the complexity of the request and current support workload.

The latest versions of documentation, manuals, software updates, and additional technical resources are available on the official Telemetry Balkan website:

www.telemetrybalkan.com

In addition to community support, Telemetry Balkan also provides commercial engineering and technical services, including:

- Custom robotic system development
- Hardware and software integration
- Platform customization and enhancement
- Autonomous navigation system development
- AI/ML integration
- Industrial and research deployment support
- Dedicated technical consulting and maintenance services

Organizations or individuals requiring professional support, commercial integration services, or custom development are encouraged to contact the Telemetry Balkan team directly through the support email or the official website.



8. Conclusion

The O2D R5 robotic platform combines compact mechanical design, modular electronics, and modern AI-capable computing into a versatile autonomous robotics system. By following the procedures described in this manual, users can successfully assemble, wire, configure, and launch the robot for software development and operational testing.

The modular architecture of the O2D R5 allows future expansion and customization, including additional sensors, improved compute modules, alternative motor configurations, and advanced autonomous navigation capabilities. The use of containerized software deployment simplifies maintenance, software updates, and reproducible development environments across multiple robots.

After completing the assembly and software installation procedures, the robot should be fully operational and accessible through the ORB Robot Control Software web interface. Users are encouraged to validate all electrical connections, motor behavior, sensor outputs, and software services before performing autonomous operation.

Telemetry Balkan doo Beograd will continue improving the O2D platform through iterative hardware and software updates. Future revisions of this document may include troubleshooting procedures, maintenance instructions, calibration workflows, and expanded operational guidelines.